



**NIVE 800 & NIVE 1000 INBUILT
ZERO CLEARANCE BOX SUPPLEMENT INSTRUCTIONS**

MUST BE IN CONJUNCTION WITH THE INSTALLATION MANUAL FOR THE **NIVE 800** AND **NIVE 1000** MODELS.

TESTED IN ACCORDANCE WITH AS/NZS 4013:2014 and AS/NZS 2918.

Please read through this manual thoroughly before installing and starting your free-standing appliance.

Keep these instructions for future reference.

Zero Clearance Parts List

Check all the parts are supplied before beginning the assembly.



1 x Top Panel



1 x Bottom Panel

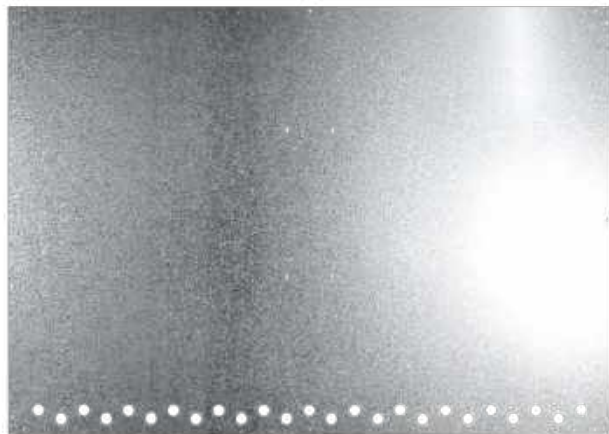

1 x Back Panel



2 x Flue Brackets



1 x Back Bracket



2 x Side Panels (RHS/LHS)



8 x Stand Vertical Brackets



4 x Bottom Brackets



2 x Side Fill-Ins



8 x Stand Horizontal Long Brackets



8 x Stand Horizontal Short Brackets

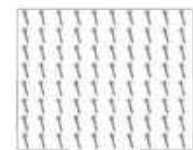

84 x Self-Tapping Screw

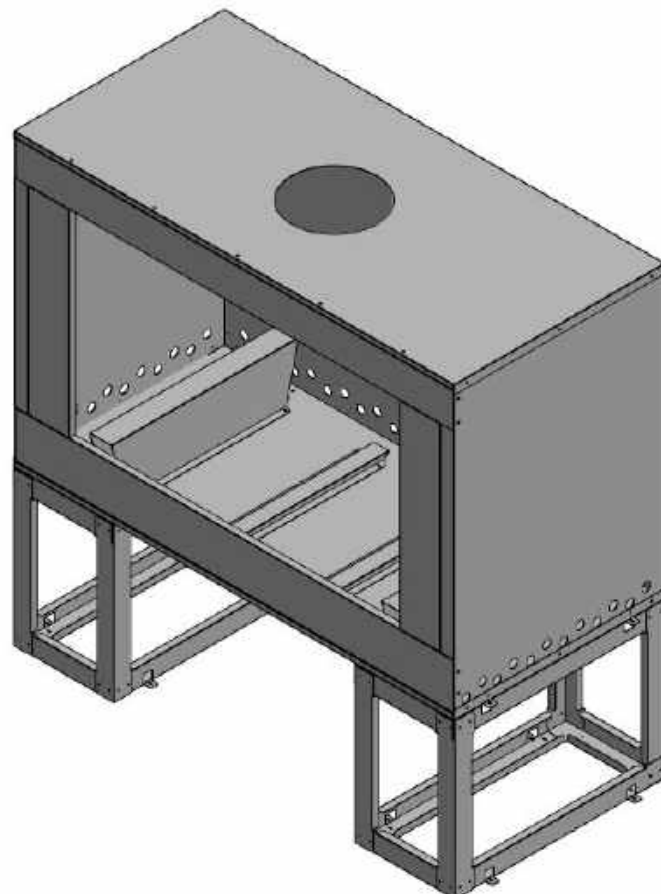
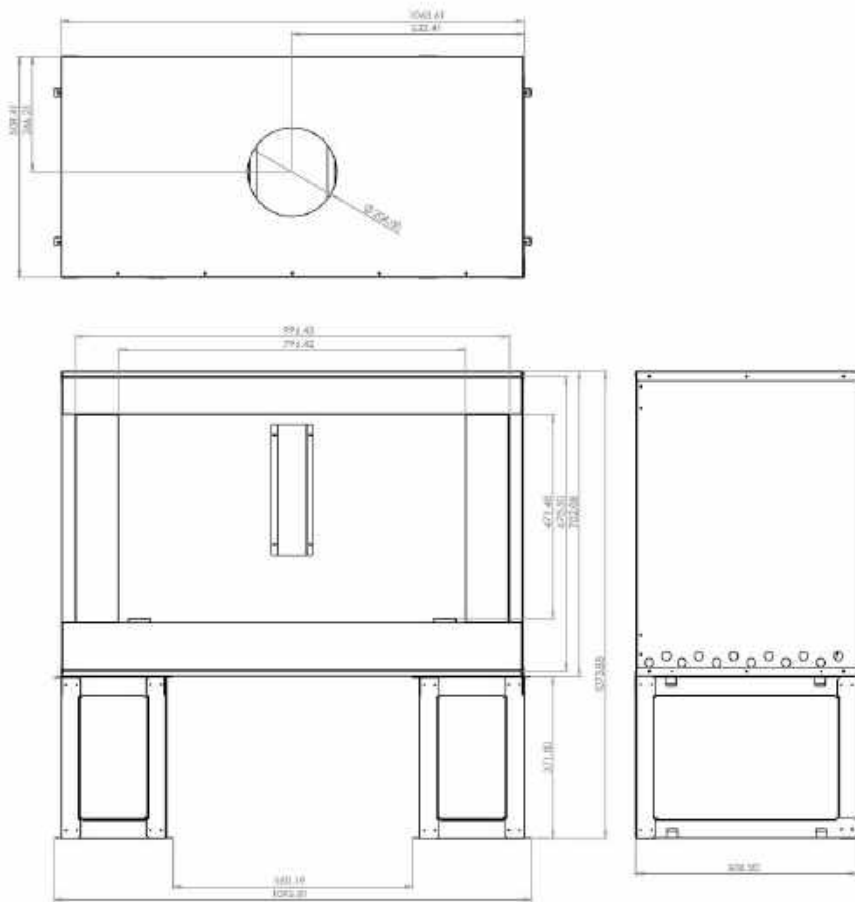

Assembly Instructions

Step 1: Assemble the Stand

- 1.1 Start by making the four side frames for the stand first. For each end, you will use 2 x Stand Horizontal Short Brackets and 2 x Stand Vertical Brackets. Lay them out as seen in the image below.



- 1.2 Line up the corners by aligning the holes with the wider fold in the leg and use the 8 x Self-Tapping Screws on each hole.



- 1.3 Repeat for the opposite side. You should have 4 x Stand Sides.

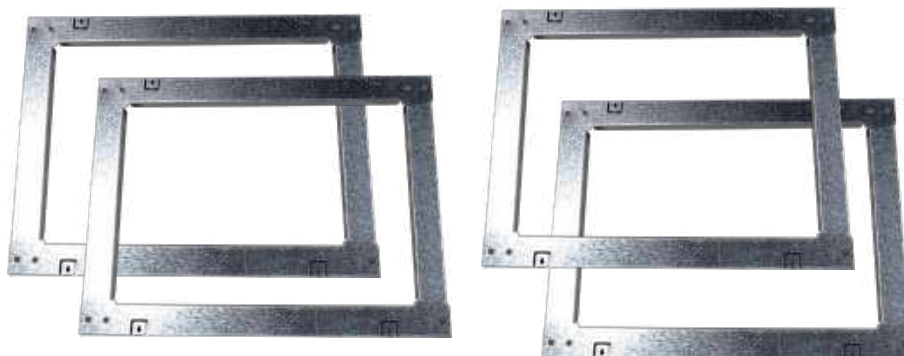

- 1.4 Now you can join the two Stand Sides with the Stand Horizontal Long Brackets. You can line them up with the Long Brackets go on the outside of each corner. Start by lining up one side first, then move to the other side.



- 1.5 You will then need 48 x Self-Tapping Screws, to join everything and make the stand. Note that the Bottom Tabs in the stand can also be used to fix the frame to the floor. Ensure the base is secured to the floor, using fixings appropriate for the flooring structure. The floor must be able to support the weight of the heater, flue, and fuel load, which is approximately 300kg. Refer to Step 2.2, to see how the Tabs can be bent out.



- 1.6 This concludes the assembly for the Stand, and you can now prepare for the assembly of the Zero Box. You will begin assembly with the stand, so if you haven't secured your stand down, we suggest you move it close to where the unit will be installed with the Zero Box, if you haven't so already, as the Zero Box can be quite heavy to move around.

Step 2: Attaching the Stand to the Zero Box

2.1 Place the Bottom Panel, on top of the completed Stand. The front of the bottom panel should be flat in line with the front stand face.



2.2 Flip up the Top Tabs to stop the Bottom Plate from moving around. Ensure you do this on both sides, there should be a total of four Top Tabs.



2.3 Once the front is lined up and the tabs are bent up, secure the Bottom Plate to the Stand by using 6 x Self Tapping Screws.



- 2.4 You can then add the 3 x Bottom Brackets to the fixed Bottom Panel. Line them up with each hole on the Bottom Panel, and then use 4 x Self Tapping Screws on each Bottom Bracket (A total of 12 x Self Tapping Screws). Note that each of the Bottom Brackets should sit under the Front Fold of the Bottom Panel.



- 2.5 Grab either the RHS/LHS Side Panel, and slot it into the appropriate sides. This is indicated with the circle cut-outs on each Side Panel, which should be on the bottom side, and the three-fold edge should be on the front side. Note the Side Panels should be placed on the inside of the Bottom Panel.



- 2.6 Screw the lined-up holes for the RHS/LHS Side Panel as shown below, you will need 5 x Self Tapping Screws for one side (A total of 10 x Self Tapping Screws). Repeat this step for the opposite side. Note only fully tighten the screws once the top is in position.

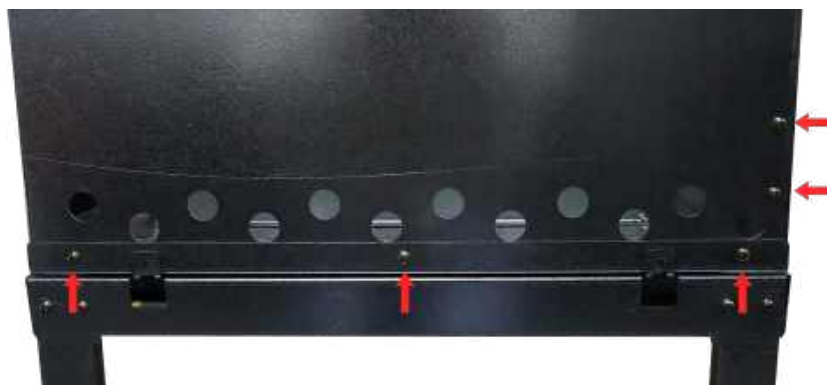

2.7 Slide the Back Panel into the inside of the Side Panels and Bottom Panel.



2.8 Line up the holes and use 9 x Self Tapping Screws. Use the circle cut-outs in the Back Panel to pull the sheet towards you, which should help when you are inserting the Self Tapping Screws. Again, don't tighten the Self Tapping Screws until the Top Panel has been placed.



2.9 You can now place the Top Panel on the top. All the folds should sit on the outside of the Side Panels and the Back Panel.



- 2.10 The holes should line up on The Top Panel, with the Side Panels and Back Panel. Then use 5 x Self Tapping Screws for the sides (A total of 10 x Self Tapping Screws) and 3 x Self Tapping Screws. If you are installing for the Loire 800, then go to Step 4 before continuing. Once the Top Panel is on, tighten all the screws.

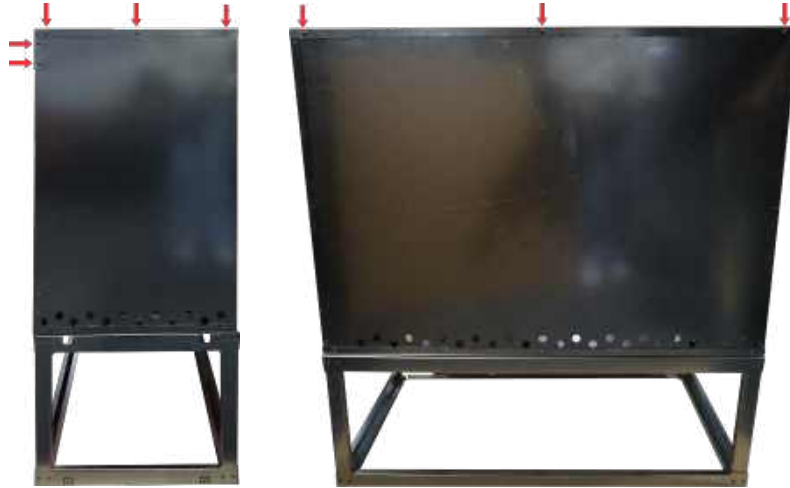

- 2.11 You can then add the Back Bracket to the Back Panel. The heater will stop when inserted up to the Back Bracket. Use 4 x Self Tapping Screws to attach the Back Bracket.



Step 3: Fitting the Flue

- 3.1 The flue should be raised off the top of the Zero Clearance Box, using the 2 x Flue Brackets. The Flue Brackets are fixed to the 152mm Flue (Inner Casing), and the upper folded u-shaped hook is fixed to the 203mm Flue (Outer Casing). You will need 3 x Self Tapping Screws for each Flue Bracket (A total of 6 x Self Tapping Screws). The 152mm Flue slides through the top of the Zero Clearance Box and sits above the heater resting on the Flue Brackets. The 152mm Flue must be sealed with a flexible sealant around the top of the Zero Clearance Box, to stop heater air from coming into the chimney chase cavity. The 203mm Flue must sit 65mm above the top of the Zero Clearance Box.



Step 4: Converting LOIRE 1000 to LOIRE 800

4.1 If you are installing the Loire 1000, then you are completed with assembly. If you are installing for the Loire 800, you will need to assemble the 2 x Side Fill-Ins before tightening the Top and Side Panels. There are four slots for each Side Fill-In, at the top and bottom.



Note: If you want to do duct work, you will need to cut your own vents on the top side of the Zero Box after it has been assembled.

Completed Zero Clearance Box with Stand for Lacunza Nive 800/1000



Import Safety and Clearance Information

Nive 1000

THERMAL CLEARANCE TESTING OF THE NIVE 1000 INBUILT AND ZERO CLEARANCE BOX

Report

The Nive 1000 Inbuilt and Zero Clearance Box installed with a 6" triple skin flue kit was tested in one position in a manner conforming to joint Australian/New Zealand Standard 2918:2018, Appendix B.

A minimum 560mm deep x 1260mm wide x 6mm thick floor protector (compressed board) should be used under the appliance base when installing the appliance (see joint AS/NZS 2918:2018 3.3.2). A minimum 1310 x 300mm x 6mm thick floor protector (compressed board) should be used in front of the enclosure base. The floor protector should extend 300mm in front of the appliance door and be placed centrally in the 1310mm width. The Thermal resistivity of the floor protector is 0.026m².K/W for 6mm thick compressed cement sheets. The appliance was installed 500mm above the floor protector.

The Nive 1000 Inbuilt and Zero Clearance Box installed with a 6" triple skin flue kit conforms to the requirements of the joint AS/NZS 2918:2018 Standard, Appendix B.

The appliance and flue system were tested at the following clearances:

1. Venting in the ceiling of the enclosure around the outer triple flue skin must be a minimum of 305,723mm², evenly spaced around the outer casing.
2. Timber framing in the ceiling cavity must be a minimum of 1325mm above the zero box and must have a minimum 305,723mm² air flow around the flue outer casing.
3. The inner galvanised casing of the flue (203mm) must be vented into the zero clearance box and be sealed to prevent venting into the enclosure.
4. The outer galvanised casing of the flue (254mm) must be raised 65mm above the zero clearance box.
5. The combustible enclosure must have 2 vents, each vent must be 50 high x 200mm wide (10,000mm² each vent). The bottom vent must be 50mm above the floor, the top vent must be 500mm below the ceiling. They must be installed on the front of the combustible enclosure and must be made of a heat resistant material.
6. Underside mantel shelf shall be no closer than 440mm from the top of the appliance hot air outlet, the mantel shelf shall extend no further than 250mm into the room.
7. Underside mantel key shall be no closer than 390mm from the top of the appliance hot air outlet, the mantel key shall extend no further than 25mm into the room.
8. Mantel uprights shall be no closer than 100mm from the side of the appliance fascia and the mantle uprights shall be no thicker than 45mm.
9. The front wall of the zero clearance box enclosure must be made of non-combustible material to a height of 1450mm above the floor protector and must extend 135mm either side of the appliance down to the floor protector on both sides of the enclosure.
10. First internal noggin must be a minimum of 300mm above the top of zero clearance box. The Noggin must not be closer than 45mm from the outer flue casing.
11. The Combustible rear wall of the enclosure must be a minimum of 50mm from the rear of the appliance zero clearance box.
12. The Combustible side walls of the enclosure must be a minimum of 100mm from the side of the appliance zero clearance box.

Nive 800

THERMAL CLEARANCE TESTING OF THE NIVE 800 STAR INBUILT AND ZERO CLEARANCE BOX

Report

The Nive 800 Star Inbuilt and Zero Clearance Box installed with a 6" triple skin flue kit was tested in one position in a manner conforming to joint Australian/New Zealand Standard 2918:2018, Appendix B.

A minimum 560mm deep x 1260mm wide x 6mm thick floor protector (compressed board) should be used under the appliance base when installing the appliance (see joint AS/NZS 2918:2018 3.3.2). A minimum 915 x 300mm x 6mm thick floor protector (compressed board) should be used in front of the enclosure base. The floor protector should extend 300mm in front of the appliance door and be placed centrally in the 915mm width. The Thermal resistivity of the floor protector is 0.026m².K/W for 6mm thick compressed cement sheets. The appliance was installed 500mm above the floor protector.

The Nive 800 Star Inbuilt and Zero Clearance Box installed with a 6" triple skin flue kit conforms to the requirements of the joint AS/NZS 2918:2018 Standard, Appendix B.

The appliance and flue system were tested at the following clearances:

1. Venting in the ceiling of the enclosure around the outer triple flue skin must be a minimum of 305,723mm², evenly spaced around the outer casing.
2. Timber framing in the ceiling cavity must be a minimum of 1325mm above the zero box and must have a minimum 305,723mm² air flow around the flue outer casing.
3. The inner galvanised casing of the flue (203mm) must be vented into the zero clearance box and be sealed to prevent venting into the enclosure.
4. The outer galvanised casing of the flue (254mm) must be raised 65mm above the zero clearance box.
5. The combustible enclosure must have 2 vents, each vent must be 50 high x 200mm wide (10,000mm² each vent). The bottom vent must be 50mm above the floor, the top vent must be 500mm below the ceiling. They must be installed on the front of the combustible enclosure and must be made of a heat resistant material.
6. Underside mantel shelf shall be no closer than 440mm from the top of the appliance hot air outlet, the mantel shelf shall extend no further than 250mm into the room.
7. Underside mantel key shall be no closer than 390mm from the top of the appliance hot air outlet, the mantel key shall extend no further than 25mm into the room.
8. Mantle uprights shall be no closer than 90mm from the side of the appliance fascia and the mantle uprights shall be no thicker than 45mm.
9. The front wall of the zero clearance box enclosure must be made of non-combustible material to a height of 1450mm above the floor protector and must extend 235mm either side of the appliance down to the floor protector on both sides of the enclosure.
10. First internal noggin must be a minimum of 300mm above the top of zero clearance box. The Noggin must not be closer than 80mm from the outer flue casing.
11. Combustible material to the rear wall of the enclosure must be a minimum of 50mm from the rear of the appliance zero clearance box.
12. Combustible material to side walls of the enclosure must be a minimum of 100mm from the side of the appliance zero clearance box.

Clearance Diagrams

Nive 800

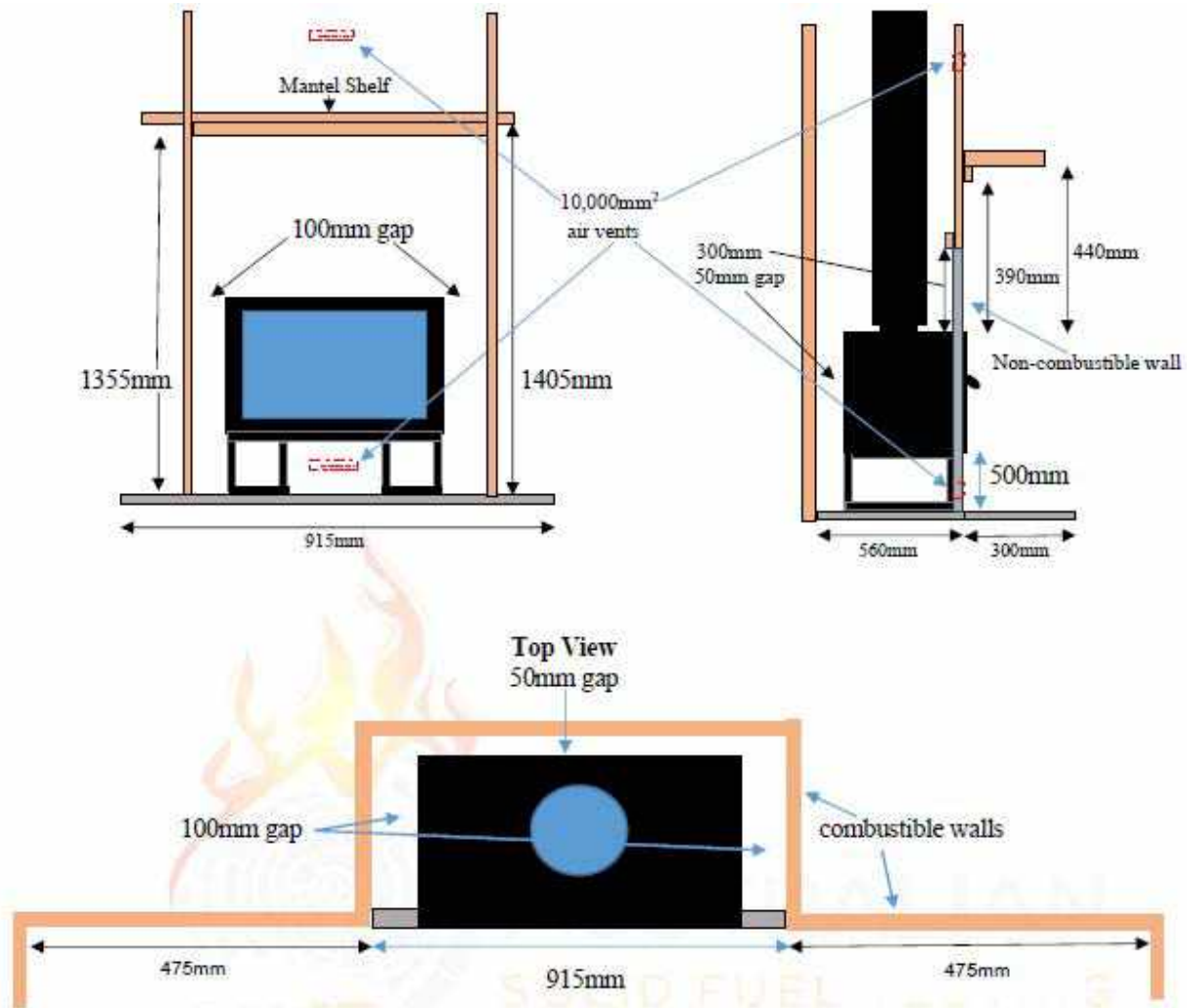

Nive 1000

