



# LACUNZA

*Natural comfort*

**50**  
YEARS WITH YOU  
**LACUNZA**





## Lacunza is... **HISTORY**

Our roots lie in the Sakana valley, in the Navarre region of Spain. We were born and raised here, and our business is marked by more than 50 years of work and a non-stop forward path.

For more than half a century, we have forged our business' unique personality based on the sustainability of the environment, innovation, technology, design and customer orientation.

From the original iron foundry and subsequent cookstove and fireplace factory, LACUNZA has undergone a remarkable evolution and development. This is evidenced in our range of products, models, materials and energy sources, as well as the continued incorporation of quality, innovation and design into all our products.

## Lacunza is... **COMMITMENT**

At LACUNZA, we have set a benchmark for cookstoves, wood-burning stoves and fireplaces. We design, manufacture and market all our products.

Our greatest strength is our personnel and their commitment to our company. We strive to foster respect for the social, economic and environmental surroundings and through this, we give back to the environment.

## Lacunza is... **SUSTAINABILITY**

At LACUNZA, the importance of taking care of our forests is clear to us. Our manufacturing goal is for all our products to have the greatest energy efficiency with the smallest ecological footprint possible. We care for and replant forests that provide one of the greatest sources of heat and energy: wood.

# In-Built



# Silver



Silver 800



Silver 1000

## CHARACTERISTICS

- Carbon steel insert in 800 and 1000mm options
- Black Vermiculite interior panels
- Two 5 speed optional centrifugal fans 300m<sup>3</sup> p/h
- Removeable ash pan
- Full glass door
- 200mm Flue connection
- Double combustion
- Includes 4 sided colour coded frame
- 800 Silver = 12 kW/h EUR
- 1000 Silver = 14 kW/h EUR
- Fully certified to AS/NZS 4012, 4013 and 2918
- Overnight burn up to 9,5 hours
- Heating Capacity up to: 250sqm (For 800 model), 350sqm (For 1000 model)
- Zero Clearance Box available
- Refractory brick and cast iron internal base
- Hot Air Ducts not available in Australia



Optional Fans Digitally Controlled

## Loire



Loire 800



Loire 1000

### CHARACTERISTICS

- Carbon steel insert in 800 and 1000mm options
- Vermiculite interior panels with cast iron grate
- Loire 800 Two 5 speed fully controlled centrifugal fans
- Loire 1000 Four 5 speed fully controlled centrifugal fans
- Loire 800 150mm Flue connection
- Loire 1000 200mm Flue connection
- Optimal combustion
- Anti-stain glass
- Overnight burn up to 12 hours
- Heating Capacity up to: 250sqm (For 800 model), 350sqm (For 1000 model)
- Heat output 12 kW/h (Loire 800) 14 kW/h (Loire 1000)
- Available with Zero Clearance Box
- Fully certified to AS/NZS 4012, 4013 and 2918
- External air intake possible

## Nickel Double Sided



Nickel 800



Nickel 1000

### CHARACTERISTICS

- Carbon steel double sided insert in 800 and 1000mm options
- Black vermiculite interior panels
- Black refractory stone base
- Stainless steel removeable ash pan
- Full glass doors opening from both sides
- 200mm or reduced to 180mm flue connection
- Double combustion control
- Includes two 4 sided colour coded frames
- 800 Nickel = 9,9 to 15 kW/h
- 1000 Nickel = 15,6 to 22 kW/h
- Fully certified to AS/NZS 4012, 4013 and 2918
- Overnight burn up to 12 hours
- Heating Capacity up to: 250sqm (For 800 model), 350sqm (For 1000 model)
- Zero Clearance Box available
- Refractory brick and cast iron internal base
- External air intake possible with supplied connector

# Freestanding



# Atlantic 603



## CHARACTERISTICS

- Steel stove 60cm wide and 85cm high
- Black Vermiculite interior
- Full glass door
- Stainless steel ash pan
- Cast Iron grid
- Double combustion control with air wash
- 150mm flue top connection
- Atlantic 600 = 12 kW / h EUR
- Fully certified to AS/NZS 4012, 4013 and 2918
- Overnight Burn time up to 9.5 hrs
- Heating Capacity up to 240sqm
- Three air controls for primary, secondary and double combustion
- Includes rear heat shield



## Committed to **QUALITY**

We are a company focused on the design, manufacture and marketing of cook stoves, wood-burning stoves and fireplaces. Through a Quality Management System based on ISO 9001, we undertake to comply with applicable requirements and to continually improve the effectiveness of the Quality Management System.

## Atlantic 613



## Silver F/S



Atlantic 613

### CHARACTERISTICS

- Steel stove 60cm wide and 110cm high
- Black Vermiculite interior
- Full glass door
- Stainless steel ash pan
- Cast Iron grid
- Double combustion control with air wash
- 150mm flue top connection
- Atlantic 613 = 9,1 to 13 kW/h EUR
- Fully certified to AS/NZS 4012, 4013 and 2918
- Overnight Burn time up to 10.5 hrs
- Heating Capacity up to 290sqm
- Three air controls for primary, secondary and double combustion
- Includes rear heat shield

### Dedication to **SERVICE**

Our main commitment to our customers is to offer them more than the guaranteed quality of our products. Our commitment and proposal is to make our services synonymous with trust and quick, comfortable and efficient relationships. At LACUNZA, we openly seek to promote mutual loyalty and offer our own Technical Assistance Service to ensure that the product experience is always the best.

### CHARACTERISTICS

- Carbon steel in 800 and 1000mm options
- Black Vermiculite interior panels
- Two 5 speed optional centrifugal fans 300m<sup>3</sup> p/h
- Stainless steel ash pan
- Full glass door
- 200mm or reduced to 180mm flue connection
- Double combustion control
- 800 Silver = 6,7 to 12 kW/h
- 1000 Silver = 7,9 to 14 kW/h
- Fully certified to AS/NZS 4012, 4013 and 2918
- Overnight Burn up to 12 hours
- Heating Capacity up to: 250sqm (For 800 model), 350sqm (For 1000 model)
- Refractory brick and cast iron internal base



Optional Fans Digitally Controlled

## Silver F/S W/B



## Verona F/S



### CHARACTERISTICS

- Carbon steel in 800 and 1000mm options
- Black Vermiculite interior panels
- Two 5 speed optional centrifugal fans 300m<sup>3</sup> p/h
- Stainless steel removeable ash pan
- Full glass door
- 200mm or reduced to 180mm flue connection
- Double combustion control
- 800 Silver = 6,7 to 12 kW/h
- 1000 Silver = 7,9 to 14 kW/h
- Fully certified to AS/NZS 4012, 4013 and 2918
- Overnight Burn up to 12 hours
- Heating Capacity up to: 250sqm (For 800 model), 350sqm (For 1000 model)
- Refractory brick and cast iron internal base



Optional Fans Digitally Controlled



Verona 800



Verona 1000

### CHARACTERISTICS

- Carbon steel double sided available in 800 and 1000mm
- Black vermiculite panels
- Black refractory stone base
- Stainless steel removeable ash pan
- Full glass doors
- 200mm Flue connection
- Double combustion control
- 800 Verona =15 kW/h
- 1000 Verona = 15,6 to 22 kW/h
- Fully certified to AS/NZS 4012, 4013 and 2918
- Overnight Burn up to 12 hours
- Heating Capacity up to: 250sqm (For 800 model), 350sqm (For 1000 model)
- Refractory brick and cast iron internal base
- External Air Option

## Loire F/S



## Loire F/S W/B



Loire F/S 800



Loire F/S 1000



Included Fans Digitally and Manually Controlled

### CHARACTERISTICS

- Carbon steel insert in 800 and 1000mm options
- Black Vermiculite interior panels
  - Loire 800 : Fan Kit: 2 Fan set manual and automatic modes 5 speed touch control pad with remote control
  - Loire 1000: Fan Kit: 4 Fan set manual and automatic modes 5 speed touch control pad with remote control
  - Removeable ash pan
  - Full glass door
  - Optimal combustion
  - Anti-stain glass
  - 50mm Rear Clearance needed
  - Loire 800 150mm Flue connection
  - Loire 1000 200mm Flue connection
  - Loire 800 = 12 kW/h EUR
  - Loire 1000 = 14 kW/h EUR
  - Overnight burn up to 12 hours
  - Heating Capacity up to: 250sqm (For 800 model) 350sqm (For 1000 model)
  - Refractory brick and cast iron internal base
  - Hot Air Ducts available
  - External air intake possible
  - Fully certified to AS/NZS 4012, 4013 and 2918



Loire F/S WB 800



Included Fans Digitally and Manually Controlled

### CHARACTERISTICS

- Carbon steel insert in 800 and 1000mm options
- Black Vermiculite interior panels
  - Loire 800 : Fan Kit: 2 Fan set manual and automatic modes 5 speed touch control pad with remote control
  - Loire 1000: Fan Kit: 4 Fan set manual and automatic modes 5 speed touch control pad with remote control
  - Removeable ash pan
  - Full glass door
  - Optimal combustion
  - Anti-stain glass
  - 50mm Rear Clearance needed
  - Loire 800 150mm Flue connection
  - Loire 1000 200mm Flue connection
  - Loire 800 = 12 kW/h EUR
  - Loire 1000 = 14 kW/h EUR
  - Overnight burn up to 12 hours
  - Heating Capacity up to: 250sqm (For 800 model) 350sqm (For 1000 model)
  - Refractory brick and cast iron internal base
  - Hot Air Ducts available
  - External air intake possible
  - Fully certified to AS/NZS 4012, 4013 and 2918

# Verona F/S Wood Box and Pedestal

# Technical informations



Verona 800 Pedestal

## CHARACTERISTICS

- Carbon steel double sided in 800 and 1000mm
- Black vermiculite panels
- Black refractory stone base
- Removeable ash pan
- Full glass doors
- 200mm Flue connection
- Double combustion control
- 800 Verona = 15 kW/h EUR
- 1000 Verona = 20 kW/h EUR
- Fully certified to AS/NZS 4012, 4013 and 2918
- Overnight Burn time up to 12 hrs
- Heating Capacity up to 350 sqm
- Refractory brick and cast iron internal base
- External air intake possible with supplied connector

We are a company focused on the design, manufacture and marketing of cook stoves, wood-burning stoves and fireplaces. Through a Quality Management System based on ISO 9001, we undertake to comply with applicable requirements and to continually improve the effectiveness of the Quality Management System.

Model	External dimensions (excluding finishing frame for in built) Width * Height * Depth	Efficiency % EUR	Efficiency % AUS	Heating Capacity Up to	O/Night Burn Up to (hours)	g / kg Emissions	Weight kg	Flue Size mm	Hearth Thickness	Front Hearth	Rear Hearth	Zero Clearance Box	Fan Sets
Silver 800 Inbuilt	892*611*445	80	70	250sqm	10	0,9	107	200	^	300	N/A	Yes	Optional
Silver 1000 Inbuilt	1092*611*445	80	65	300sqm	12	0,7	132	200	^	300	N/A	Yes	Optional
Silver 800 Freestanding	800*520*445	80	70	250sqm	10	0,9	107	200	25mm**	300	***250	N/A	Optional
Silver 1000 Freestanding	1000*520*445	80	65	300sqm	12	0,7	132	200	18mm**	300	225	N/A	Optional
Silver 800 Wood Box	800*892*447	80	70	250sqm	10	0,9	137	200	25mm**	300	***250	N/A	Optional
Silver 1000 Wood Box	1000*892*447	80	65	300sqm	12	0,7	162	200	18mm**	300	225	N/A	Optional
Nickel 800 Inbuilt	892*611*510	80	64	300sqm	10	0,9	130	200	18mm**	300	N/A	Yes	N/A
Nickel 1000 Inbuilt	1092*611*510	75	60	350sqm	12	0,9	140	200	18mm**	300	N/A	Yes	N/A
Verona 800 Freestanding	842*618*515	80	64	300sqm	10	0,9	140	200	18mm**	300	N/A	N/A	N/A
Verona 1000 Freestanding	1042*618*515	75	60	350sqm	12	0,9	160	200	18mm**	300	N/A	N/A	N/A
Verona 800 Wood Box	842*951*515	80	64	300sqm	10	0,9	170	200	18mm**	300	N/A	N/A	N/A
Verona 1000 Wood Box	1042*951*515	75	60	350sqm	12	0,9	190	200	18mm**	300	N/A	N/A	N/A
Verona 800 Pedestal	842*951*515	80	64	300sqm	10	0,9	165	200	18mm**	300	N/A	N/A	N/A
Verona 1000 Pedestal	1042*951*515	75	60	350sqm	12	0,9	185	200	18mm**	300	N/A	N/A	N/A
Loire 800 Inbuilt	836*616*451	80	66	200sqm	10	0,5	100	150	6mm	300	50	Yes	2 fans included
Loire 1000 Inbuilt	1036*616*451	80,5	67	250sqm	12	0,7	117	200	6mm	300	50	Yes	4 fans included
Loire 800 Freestanding	796*576*449	80	66	200sqm	10	0,5	100	150	18mm**	300	50	N/A	2 fans included
Loire 1000 Freestanding	996*576*449	80.5	67	250sqm	12	0,7	117	200	18mm**	300	50	N/A	4 fans included
Loire 800 Wood Box	796*576*449	80	66	200sqm	10	0,5	100	150	18mm**	300	50	N/A	2 fans included
Loire 1000 Wood Box	996*576*449	80.5	67	250sqm	12	0,7	117	200	18mm**	300	50	N/A	4 fans included
Atlantic 603 Freestanding	600*850*400	85	67	200sqm	10	0,5	90	150	6mm	300	150	N/A	N/A
Atlantic 613 Freestanding	600*1100*400	78	64	250sqm	12	0,5	125	150	18mm	700	250	N/A	N/A

Notes:

^ See relevant product Zero Clearance Box manual

\*\* Fireplace base must be a minimum of 300mm off the ground

Committed to  
**QUALITY**



## FREESTANDING MODELS - SAFETY CLEARANCES

**Atlantic 603**  
Clearance diagram Corner

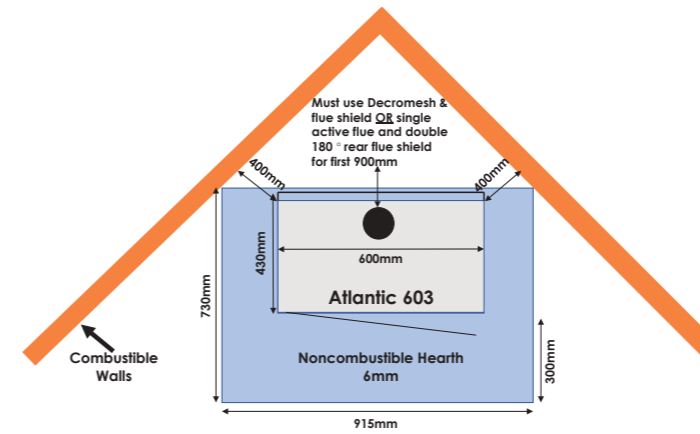

**Atlantic 603**  
Clearance diagram Corner with small shield

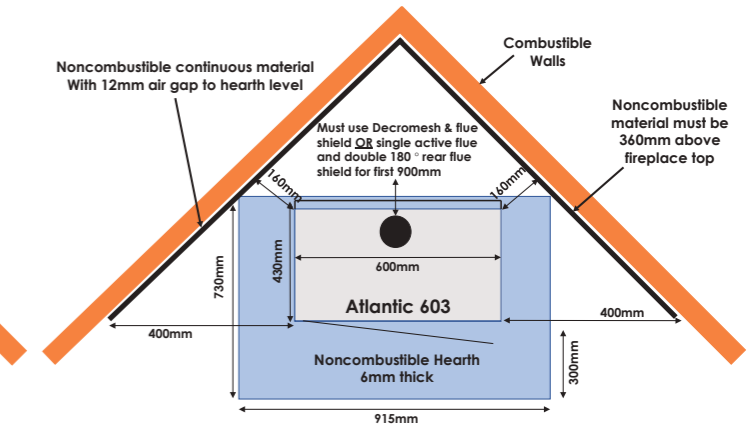

**Atlantic 603**  
Clearance Diagram

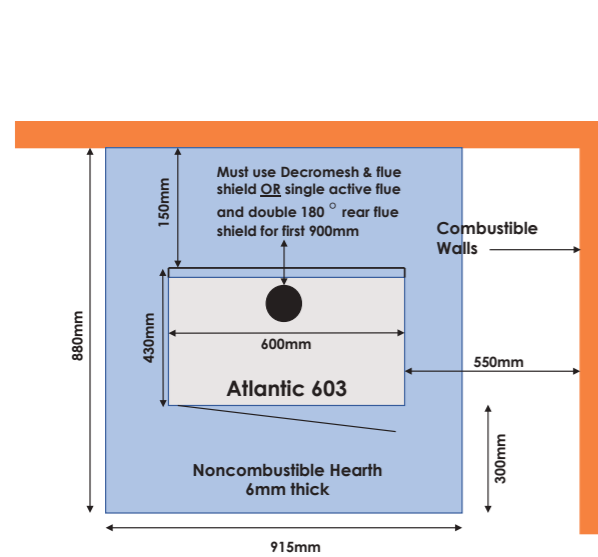

**Atlantic 603**  
Clearance Diagram with wall shield

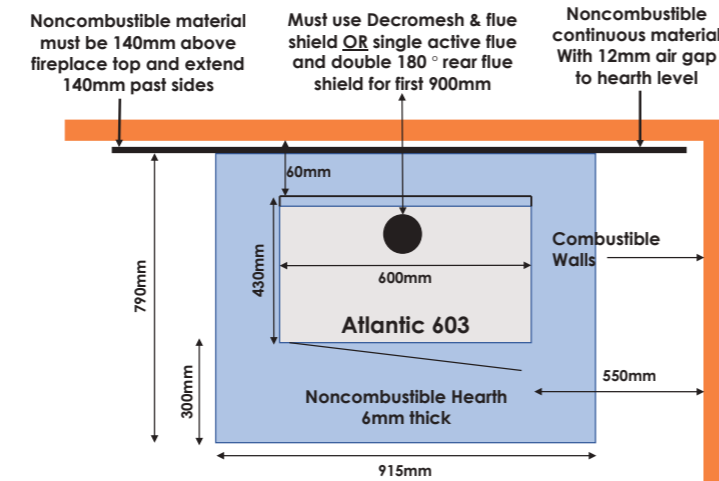

**Atlantic 613**  
Clearance diagram

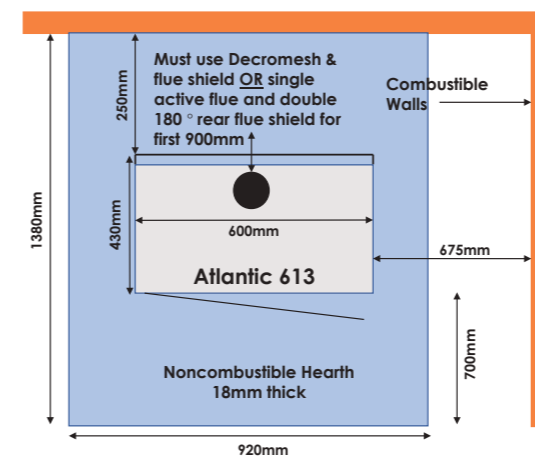

**Atlantic 613**  
Clearance diagram with small shield

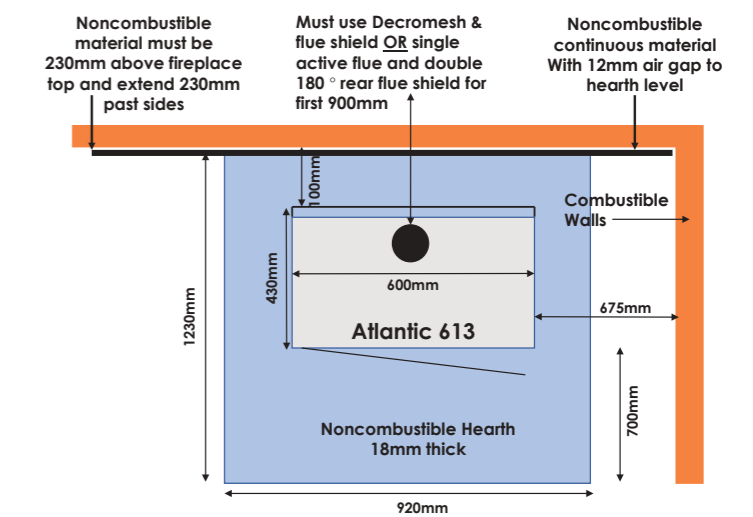

**Atlantic 613**  
Clearance diagram Corner

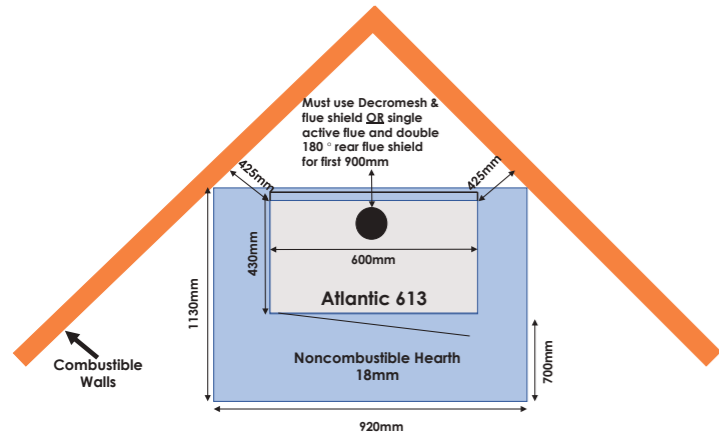

**Atlantic 613**  
Clearance diagram Corner with small shield

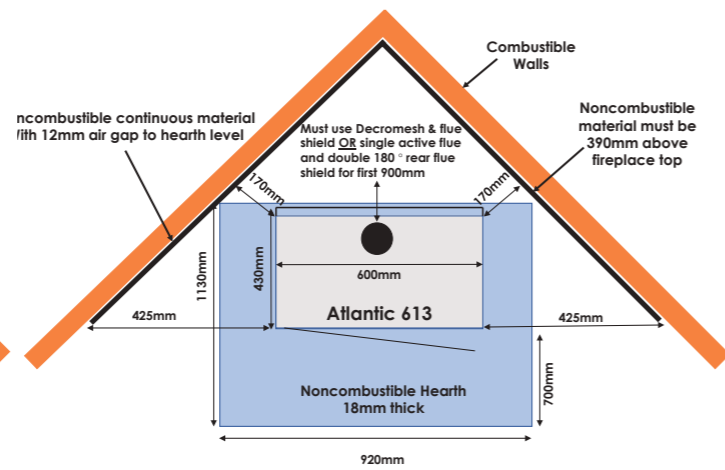

**Silver 800 F/S**  
Clearance diagram with wall shield

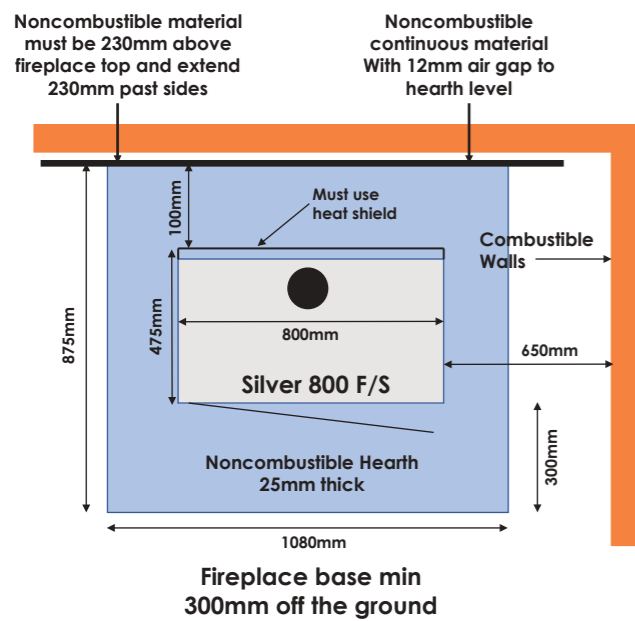

**Silver 1000 F/S**  
Clearance diagram with wall shield

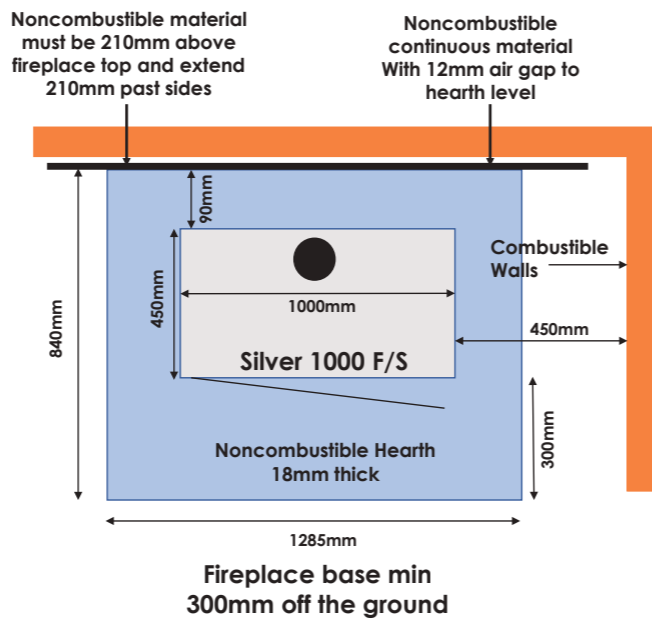

**Nickel 800 F/S**  
Clearance diagram

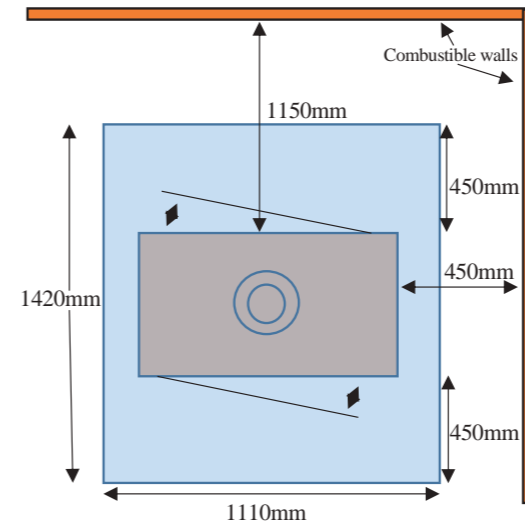

**Nickel 1000 F/S**  
Clearance diagram

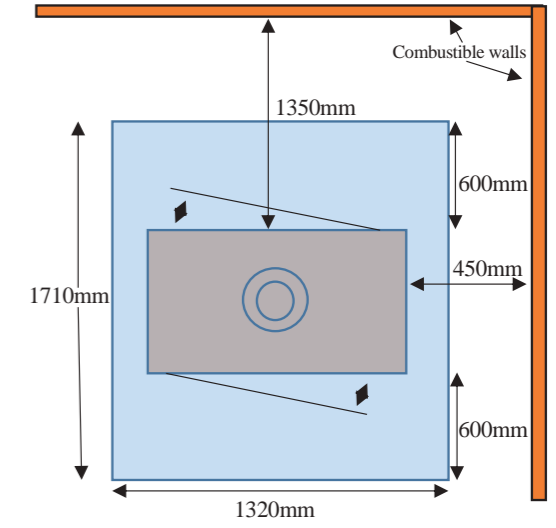

**Loire 800 F/S**  
Clearance diagram

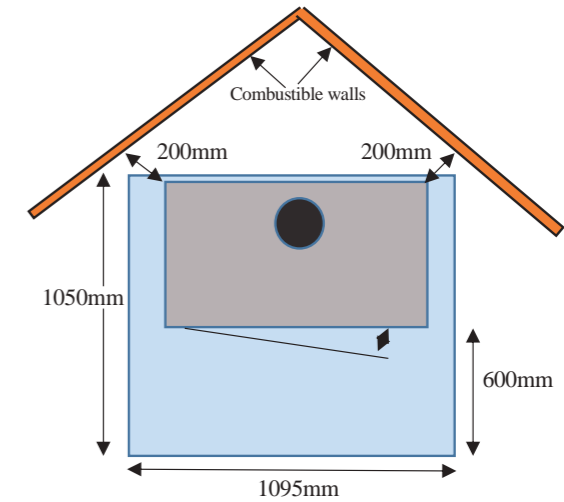
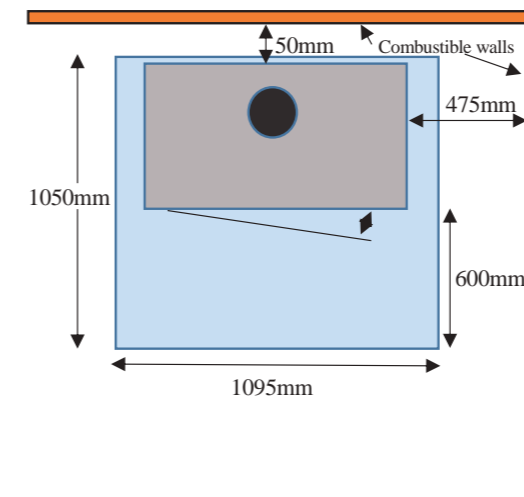

**Loire 1000 F/S**  
Clearance diagram

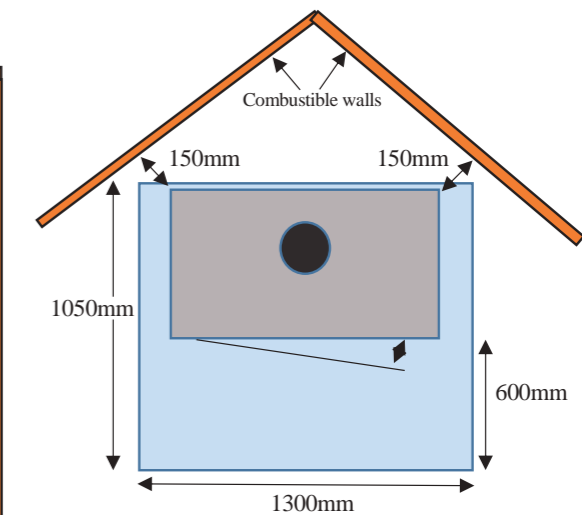
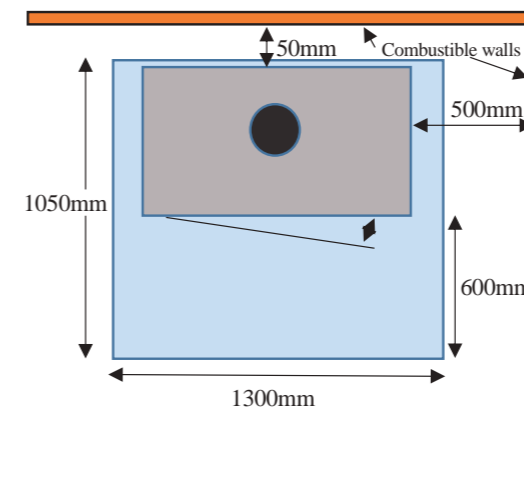



## ELEVATION SAFETY CLEARANCES

Silver 800 Hearth Size	Front in M	Thickness in MM
Flat on ground	0.6000	50
Raised 100	0.4960	50
Raised 200	0.3347	25
Raised 300	0.3000	25
Raised 400	0.3000	25
Raised 500	0.3000	25

Silver 1000 Hearth Size	Front in M	Thickness in MM
Flat on ground	0.5500	36
Raised 100	0.4220	36
Raised 200	0.3000	18
Raised 300	0.3000	18
Raised 400	0.3000	18
Raised 500	0.3000	18

Nickel and Verona 800 Hearth Size	Front in M	Thickness in MM
Flat on ground	0.6000	36
Raised 100	0.4960	36
Raised 200	0.3347	18
Raised 300	0.3000	18
Raised 400	0.3000	18
Raised 500	0.3000	18

Nickel and Verona 1000 Hearth Size	Front in M	Thickness in MM
Flat on ground	0.6000	36
Raised 100	0.4764	36
Raised 200	0.3000	18
Raised 300	0.3000	18
Raised 400	0.3000	18
Raised 500	0.3000	18

Loire 800 and 1000 Heart Size	Front in M	Thickness in MM
Flat on ground	0.6000	50
Raised 100	0.4764	36
Raised 200	0.3000	36
Raised 300	0.3000	18
Raised 400	0.3000	18
Raised 500	0.3000	18

### Loire 800 F/S

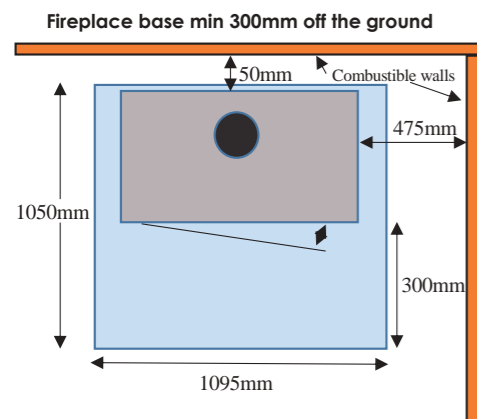

### Loire 1000 F/S

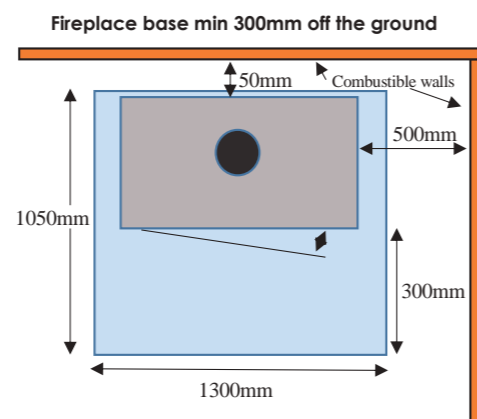

### Nickel and Verona 800

Clearance diagram

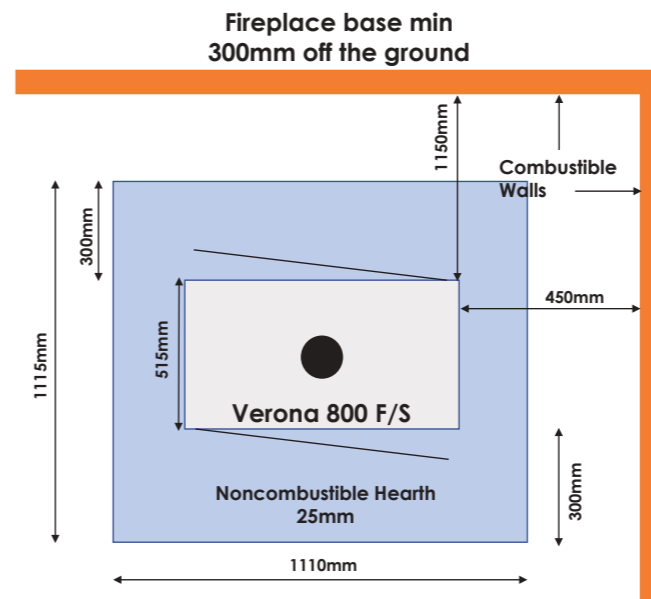

### Nickel and Verona 1000

Clearance diagram

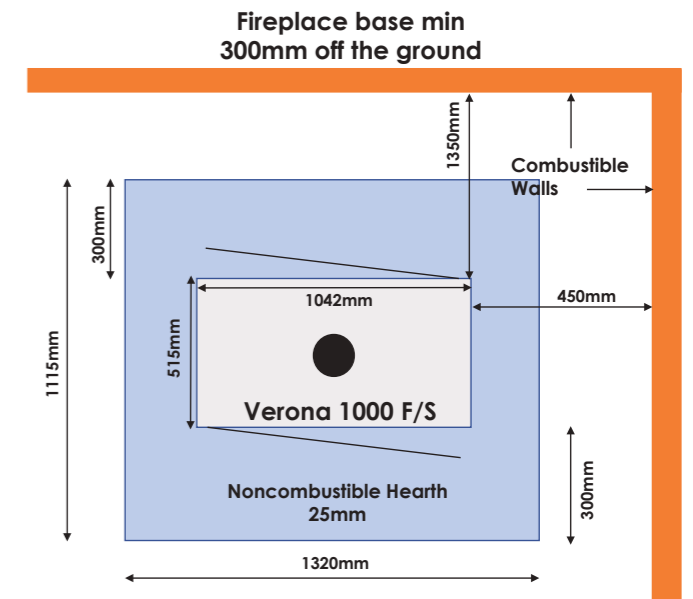

### Silver 800 F/S

Clearance diagram

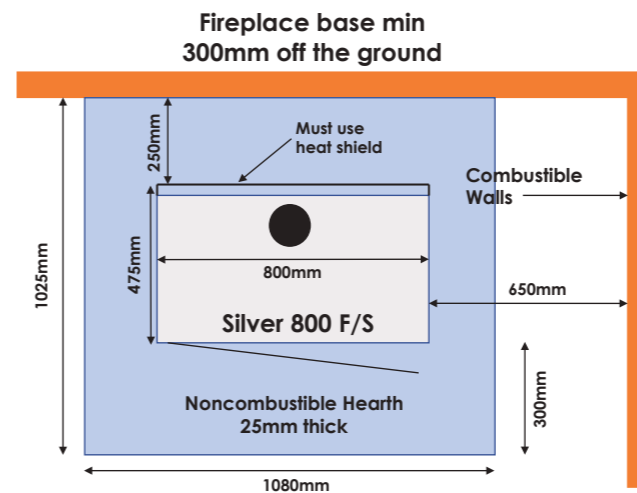

### Silver 1000 F/S

Clearance diagram

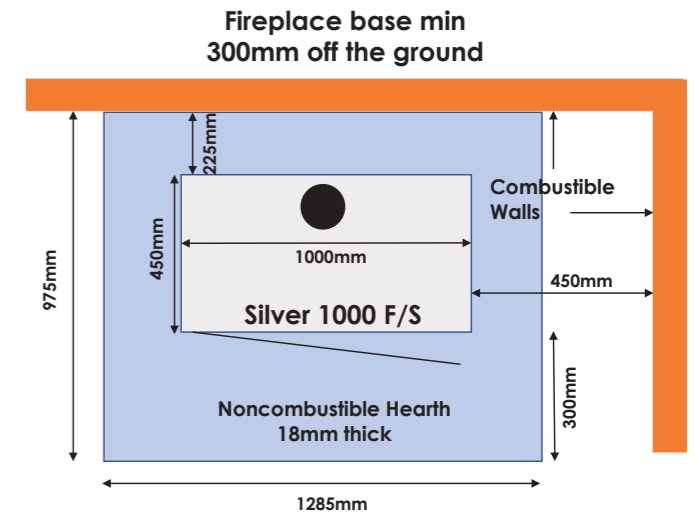

### Silver 800 F/S

Clearance diagram Corner

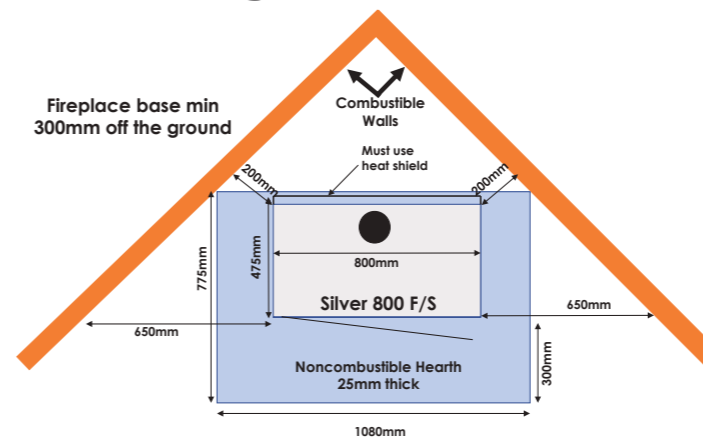

### Silver 1000 F/S

Clearance diagram Corner

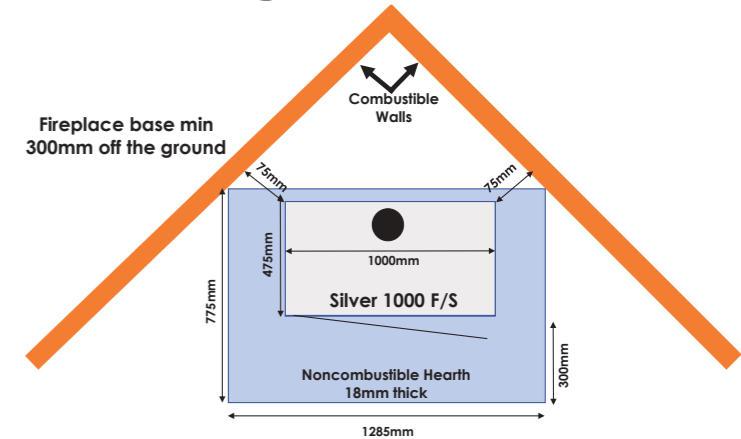



## IN-BUILT MODELS & ZERO CLEARNACE BOX - SAFETY

**Silver 1000**  
With Zero Clearance Box

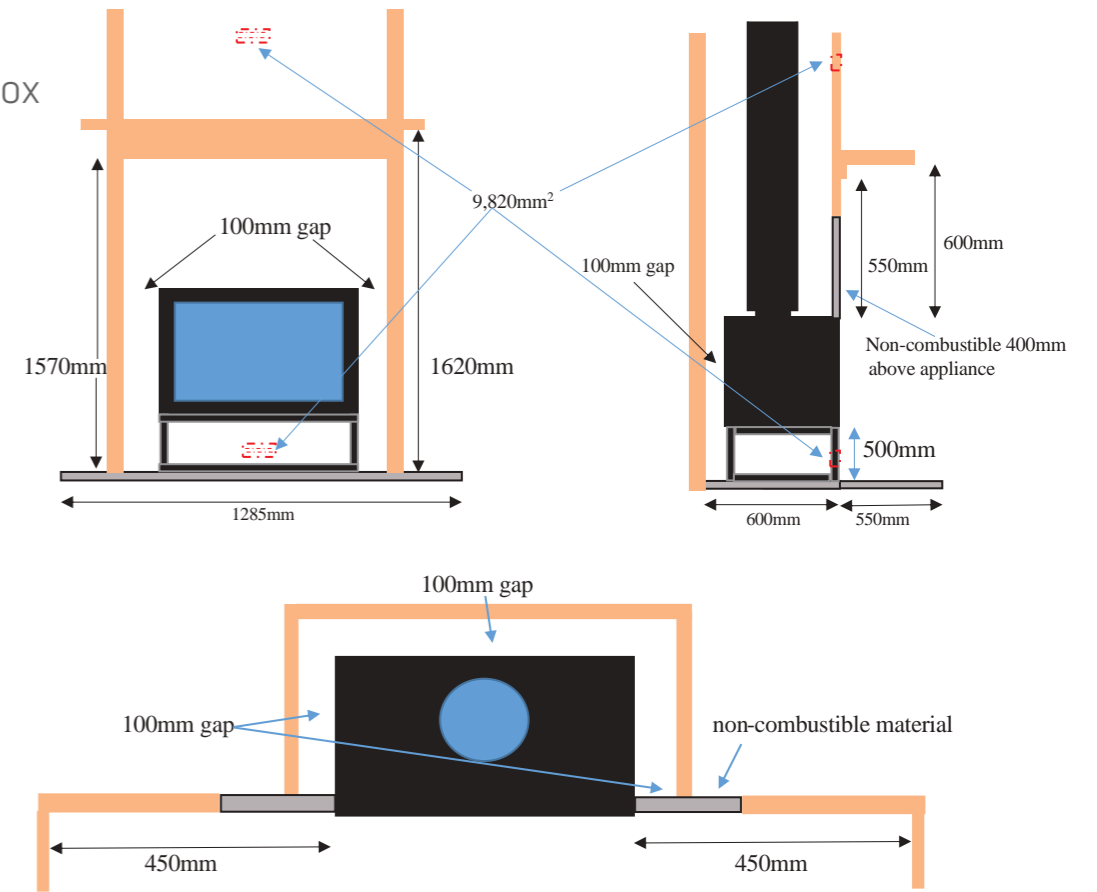

**Silver 800**  
With Zero Clearance Box

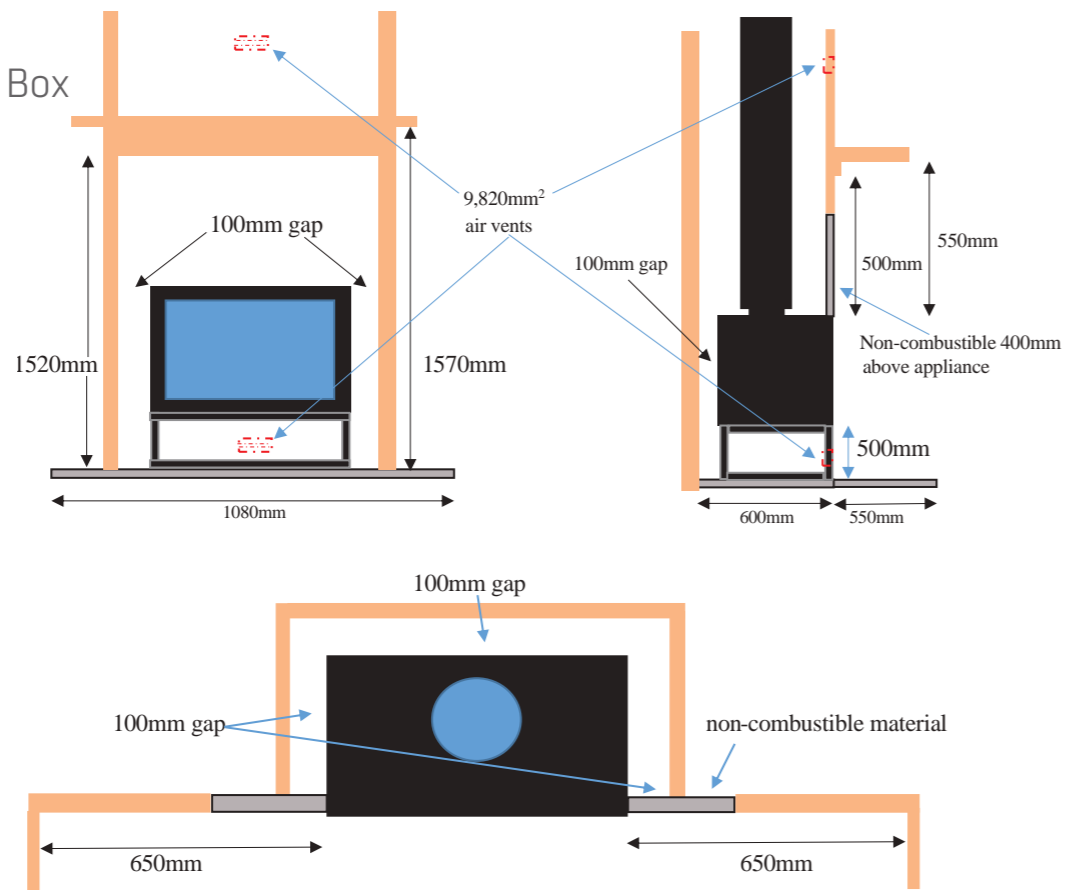

**Loire 800**  
With Zero Clearance Box

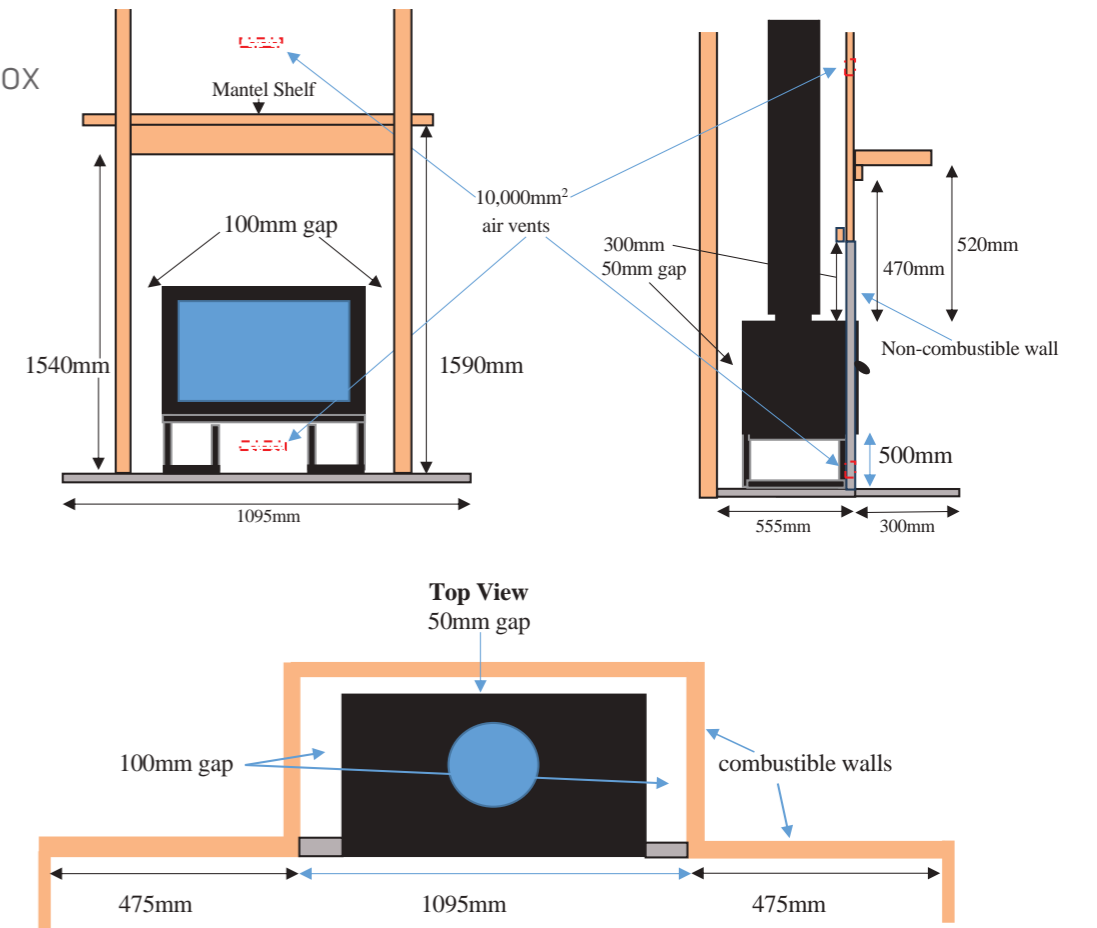

**Loire 1000**  
With Zero Clearance Box

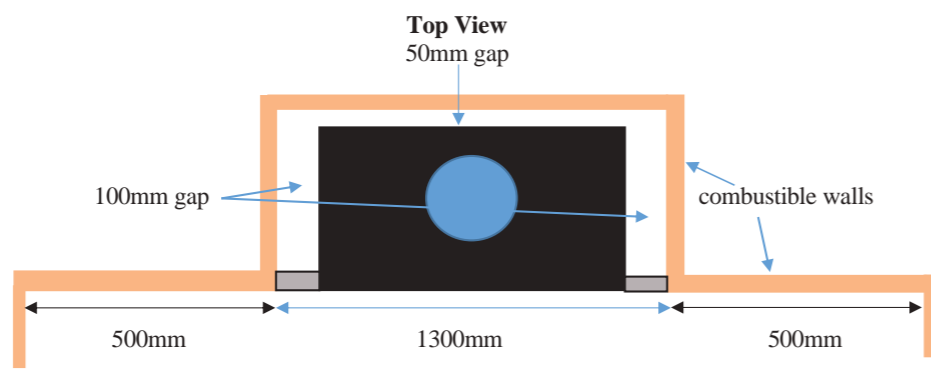
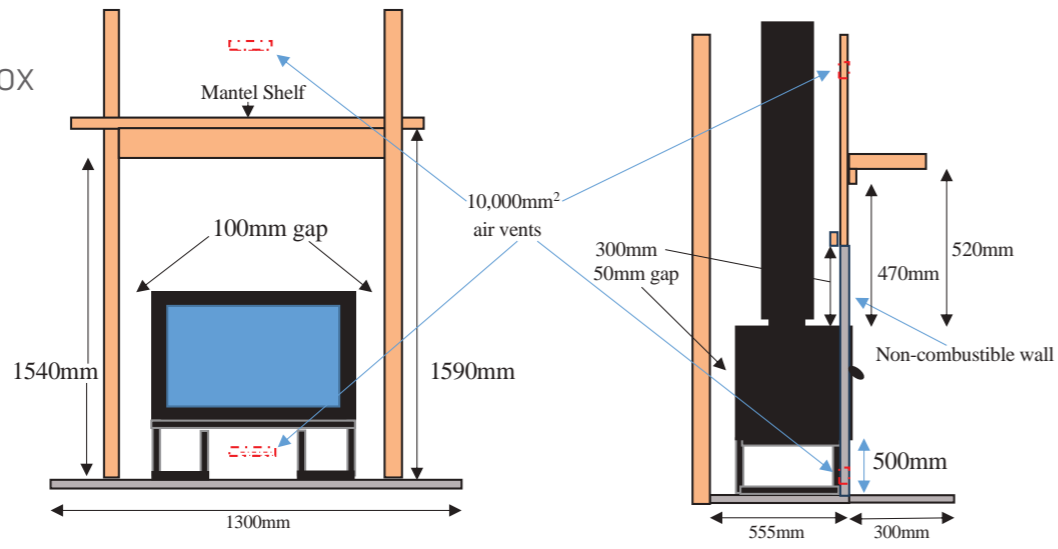

**Nickel 1000**  
With Zero Clearance Box

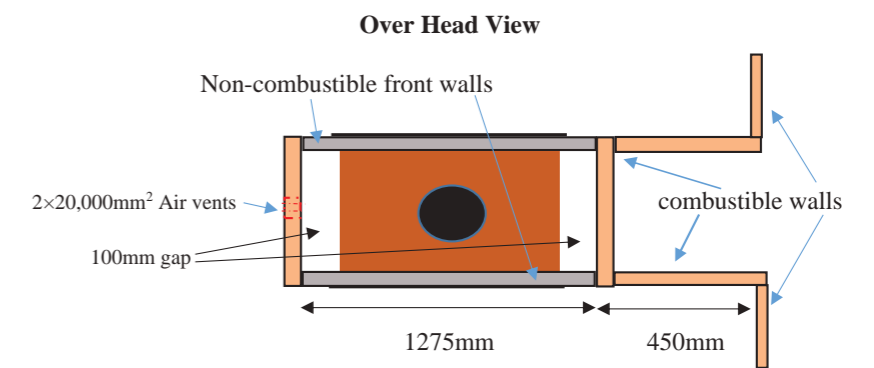
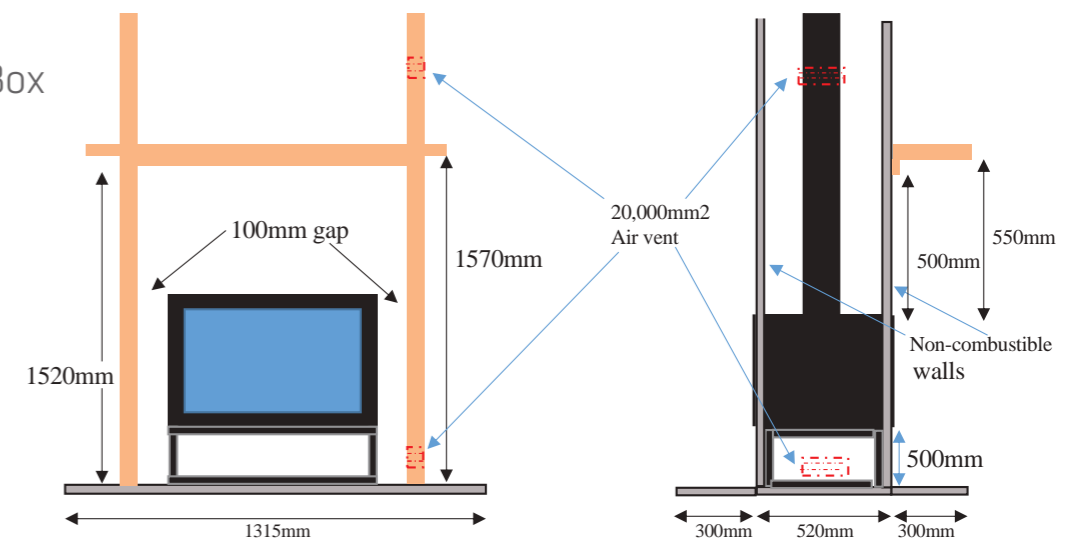

**Nickel 800**  
With Zero Clearance Box

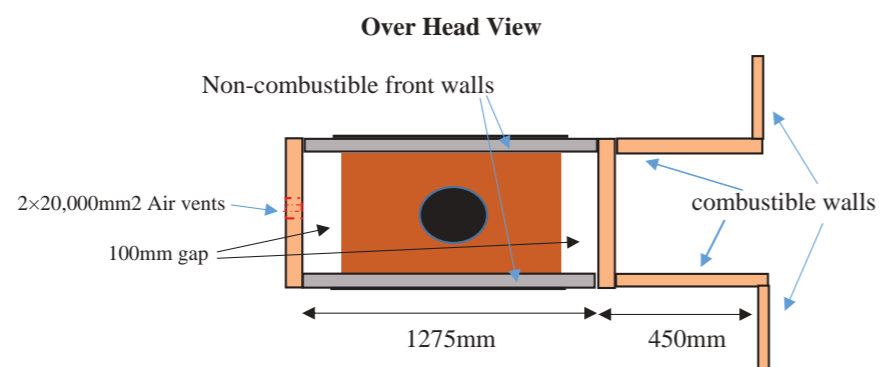
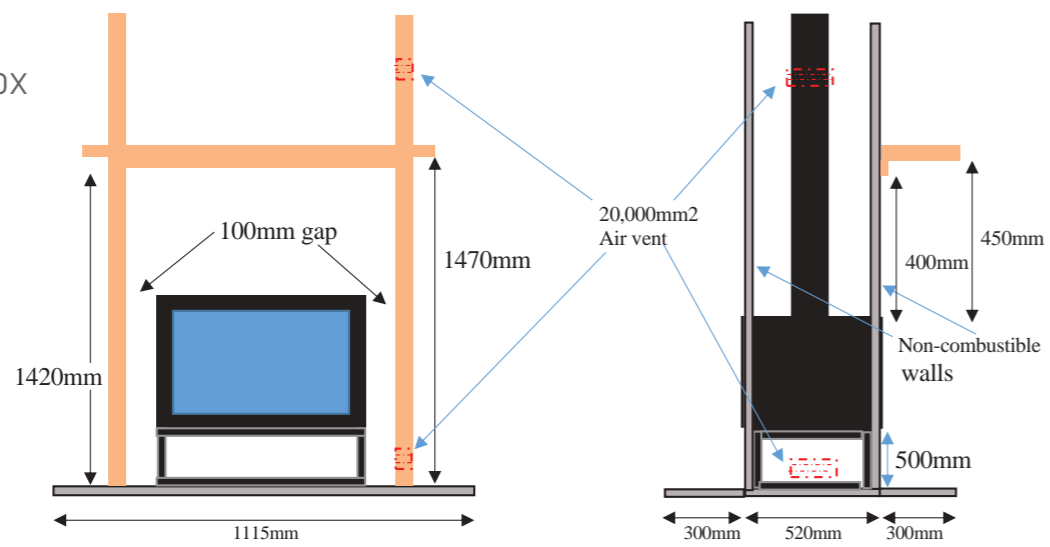



# LACUNZA

*Natural comfort*



Le label  
du chauffage  
au bois



[info@lacunza.com.au](mailto:info@lacunza.com.au)  
[www.lacunza.com.au](http://www.lacunza.com.au)

Lacunza imported by SGB Distributors(Pty) Ltd.