

# Owners Manual For All **KENT CALISTO** Wood Heaters

Freestanding and Insert models  
Small, Medium and Large sizes



Pricotech proudly supports the activities of Landcare Australia through its membership of the AHHA.

Tested and approved to Australian Standards AS/NZS 2918:2001 and AS/NZS 4013/4012:2014.

Prior to installation check with your state and local authorities regarding any specific regulations that may apply.

Please keep these instructions for future reference.  
Burn hardwood only.

# FIRST THINGS FIRST...

Congratulations on your purchase of a quality Kent wood heater. This product is designed according to strict environmental, quality and safety standards and should give you years of trouble free home heating.

Read these instructions carefully to get the most out of your heater and to ensure safe and satisfactory heater performance. In particular, we would like to draw your attention to these warnings.

## Be careful of what you burn:

- \* Use only dry, well seasoned hardwood.
- \* Do not use coal or briquettes.
- \* **WARNING: DO NOT USE FLAMMABLE LIQUIDS OR AEROSOLS TO START OR REKINDLE THE FIRE.**
- \* Do not burn garbage in the firebox as garbage can cause a dangerous soot build up and increase the amount of smoke your heater produces.
- \* Do not burn chemically treated timber as the poisonous gases given off could damage your stove.
- \* CAUTION: THE USE OF SOME TYPES OF PRESERVATIVE-TREATED WOOD AS FUEL CAN BE HAZARDOUS.
- \* Do not place any types of builders board eg fibro, cement sheeting (or any other materials not specified and tested by the manufacturer) inside the firebox.

## Protect yourself and your family from burns:

- \* **WARNING: OPEN AIR CONTROL BEFORE OPENING FIRING DOOR.**
- \* The exterior surfaces of the heater will become hot during operation. For protection of children, the elderly or infirm, provide a firescreen to prevent contact with the appliance in operation.
- \* To protect against injury from burns, use caution when operating the appliance. In particular, when loading the firebox, provide adequate protection for your hands.

## Exclusion of Liability

Whilst every care has been taken in formulating these instructions, no responsibility whatsoever will attach to and/or claim lie against, the manufacturer and/or the distributor of the heater as a result of any failure to follow the whole or any part of the instructions and/or as a result of incorrect information herein and/or any omission here from.

## Use your heater according to these instructions:

- \* CAUTION: THIS APPLIANCE SHOULD BE MAINTAINED AND OPERATED AT ALL TIMES IN ACCORDANCE WITH THESE INSTRUCTIONS.
- \* **DO NOT BURN WITH DOOR OPEN.**
- \* CAUTION: THIS APPLIANCE SHOULD NOT BE OPERATED WITH A CRACKED GLASS.
- \* Do not throw logs into the firebox. Always place logs carefully.
- \* Load logs with ends pointing to the front of the heater. This will help prevent logs rolling forward.
- \* Do not overfire as this could damage your firebox.
- \* Always leave a minimum of 25mm (1") of ash in the bottom of the firebox. Never empty it completely.
- \* **WARNING: ANY MODIFICATION OF THE APPLIANCE THAT HAS NOT BEEN APPROVED IN WRITING BY THE TESTING AUTHORITY IS CONSIDERED AS BREACHING AS/NZS 4013.**
- \* The appliance or flue system should not be modified in any way without the written approval of the manufacturer.

## The heater can get very hot, so watch obvious fire hazards:

- \* Do not place clothing or other combustible materials on top of the heater.
- \* **WARNING: DO NOT USE FLAMMABLE LIQUIDS OR AEROSOLS OR PLACE THESE IN THE VICINITY OF THIS APPLIANCE WHEN IT IS OPERATING.**
- \* **WARNING: DO NOT STORE FUEL WITHIN HEATER INSTALLATION CLEARANCES.**
- \* Do not store flammable liquids near the heater.
- \* Do not store fuel close to the stove.

# ASSEMBLING YOUR NEW HEATER

Your heater comes almost completely assembled. There is only a simple matter of placing the bricks and brick retainer, positioning the baffle plate, and the heater is ready to be installed.

## FIREBRICK PLACEMENT

There are three sizes of firebox in the Calisto range, and each has its own arrangement of firebricks. Refer to the diagrams below for your model of heater. The bricks are placed with their longest edge upright.

There will be gaps in between the firebricks. Allow the ash to settle in between - there is no need to remove the bricks when cleaning the firebox.

Brick Sizes

A - 173 x 74

B - 173 x 200

C - 119 x 200

D - 119 x 74

### Small

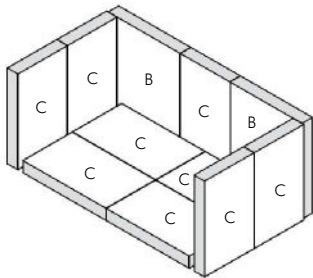

### Medium

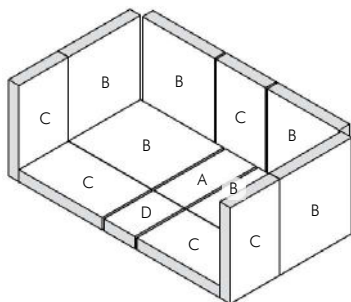

### Large

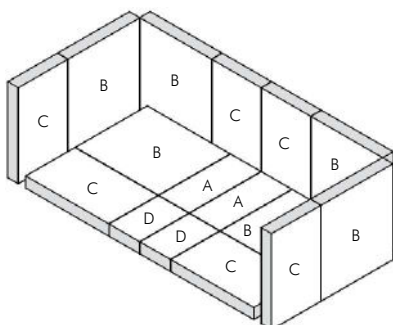

## BRICK RETAINER

To hold the firebricks in place, you should position the brick retainer bracket over the firebricks as shown below.

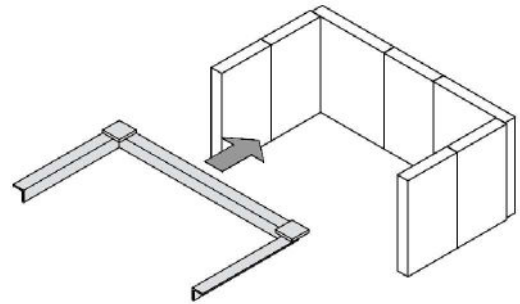

## BAFFLE PLATE

The baffle plate for your Calisto heater consists of a steel frame and a Skamolex baffle. To place the baffle into the heater, first place the Skamolex baffle into the steel frame then position into the firebox.

You may need to angle the baffle up on one side to get it through the door. You should then lift the baffle over one bracket, push it up to the top of the firebox, and then lift it over the other bracket.

Ensure the baffle plate is pushed all the way to the back of the heater.

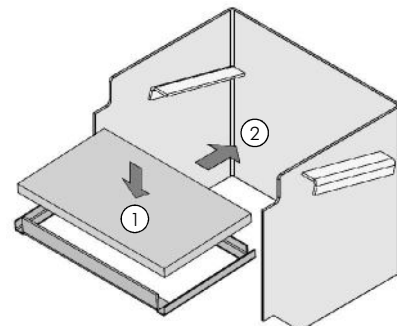

# INSTALLATION

## BEFORE BEGINNING

Before beginning the installation of your wood heater, you should note the following precautions:

- \* **WARNING: THE APPLIANCE AND FLUE-SYSTEM SHALL BE INSTALLED IN ACCORDANCE WITH AS/NZS 2918 AND THE APPROPRIATE REQUIREMENTS OF THE RELEVANT BUILDING CODE OR CODES.**
- \* **WARNING: APPLIANCES INSTALLED IN ACCORDANCE WITH THIS STANDARD SHALL COMPLY WITH THE REQUIREMENTS OF AS/NZS 4013 WHERE REQUIRED BY THE REGULATORY AUTHORITY I.E. THE APPLIANCE SHALL BE IDENTIFIABLE BY A COMPLIANCE PLATE WITH THE MARKING 'TESTED TO AS/NZS 4013.**
- \* **WARNING: ANY MODIFICATION OF THE APPLIANCE THAT HAS NOT BEEN APPROVED IN WRITING BY THE TESTING AUTHORITY IS CONSIDERED TO BE IN BREACH OF THE APPROVAL GRANTED FOR COMPLIANCE WITH AS/NZS 4013.**
- \* CAUTION: CRACKED AND BROKEN COMPONENTS, e.g. GLASS PANELS, MAY RENDER THE INSTALLATION UNSAFE.
- \* It is strongly recommended that a certified/qualified installer perform the installation.
- \* You may need to get council approval prior to installation.
- \* You should also check with your insurer for any requirements they may have.

## FLUE INSTALLATION

The correct flue system is critical to the performance of your wood heater. It must either be tested with the heater or be a default flue kit.

The flue must be sealed where it enters the heater at the flue spigot.

We recommend you use an appropriate Maxiheat flue kit.

CAUTION: MIXING OF APPLIANCE OR FLUE-SYSTEM COMPONENTS FROM DIFFERENT SOURCES OR MODIFYING THE DIMENSIONAL SPECIFICATION OF COMPONENTS MAY RESULT IN HAZARDOUS CONDITIONS. WHERE SUCH ACTION IS CONSIDERED, THE MANUFACTURER SHOULD BE CONSULTED IN THE FIRST INSTANCE.

## FLUE HEIGHT REQUIREMENTS

Your flue must extend the required height above your roof to promote sufficient draught. If the flue is not high enough, the heater will not "draw" properly causing smoke to spill back into the room.

The following conditions should be observed:

- \* The minimum height of the active flue must be 4.6 metres in length measured from the top of the hearth to the flue termination point.
- \* If the flue terminates within 3 metres from the highest point of the roof, then the flue must be a minimum of 0.6 metres above the highest point.
- \* If the flue terminates further than 3 metres from the highest point of the roof, then the flue must be a minimum of 1 metre above roof penetration.
- \* The flue must clear any ridge or obstruction within a 3 metre radius by a minimum of 1 metre.

The installer must ensure that the heater and flue are correctly and safely installed in accordance with AS/NZS 2918.

There are other variables that can affect draught (eg trees or tall buildings nearby). If you have the correct flue height and still have problems, please consult your dealer.

# INSTALLATION - FREESTANDING HEATERS ONLY

## LOCATION

Select a location for your wood heater with great care.

- \* Do not place your heater in areas of high traffic, near furniture or draperies.
- \* Check that the intended location will not interfere with ceiling joists, rafters, valleys and ridges.

## HEARTH REQUIREMENTS

If your wood heater is to be installed on carpet, timber or any other combustible material, you must place a hearth (also known as a floor protector) underneath the heater. Please observe the following:

- \* **Small and Medium:** The hearth must consist of at least 5 mm compressed fibre cement with a thermal conductivity not greater than 0.33 W/m<sup>2</sup>K
- \* **Large:** The hearth must consist of at least 15 mm compressed fibre cement with a thermal conductivity not greater than 0.33 W/m<sup>2</sup>K.
- \* It is not recommended that you make your own hearth
- \* The hearth and heater assembly must be placed on a firm and level surface.

## HEARTH CLEARANCES

It is necessary to ensure that the heater is positioned on the hearth so that the following requirements are observed.

- \* The front of the hearth should extend past the front of the heater by the distance specified by D.
- \* The side of the hearth should extend past the firebox opening by minimum 200 mm on each side.

## HEATER CLEARANCES

It is vital that the heater be installed the proper distance from combustible surfaces like wood, gyprock and curtains. These minimum distances, which you need to observe for your particular heater are stated below. The diagrams show both parallel and corner installations.

Failure to maintain these minimum distances may result in a fire for which your insurer may refuse to cover.

## REDUCED CLEARANCES

These clearances can be reduced with proper heat shielding. Basically a noncombustible surface is placed between the heater and the combustible wall. It is vital that an unobstructed air flow be maintained between the two surfaces to remove excess heat.

Parallel Installation

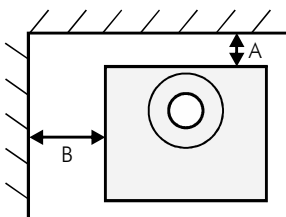

Corner Installation

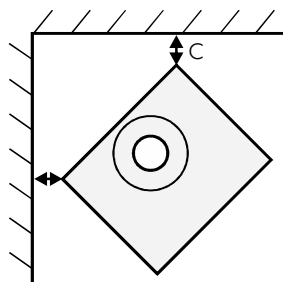

Hearth Clearances

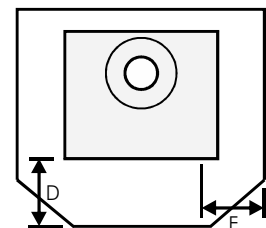

Model	A	B	C	D	E
All dimensions are in millimetres					
<b>Small Freestanding</b>					
Maxiheat Decromesh Default Flue Kit	70	120	10	325	200
Maxiheat Non-Perforated Flue Kit with inner rear shield	70	150	10	300	200
<b>Medium Freestanding</b>					
Maxiheat Decromesh Default Flue Kit	70	240	50	300	200
Maxiheat Non-Perforated Flue Kit with inner rear shield	70	240	50	300	200
<b>Large Freestanding</b>					
Maxiheat Decromesh Default Flue Kit with heat shield on the outside (back) of Decromesh	150	400	200	470	200
Maxiheat Non-Perforated Flue Kit with inner rear shield	150	400	100	300	200

# INSTALLATION - INSERT HEATERS ONLY

**WARNING: This appliance and flue MUST be installed in a full masonry fireplace, and must be installed by a qualified wood heater installer according to the latest version of AS2918.**

## FIREPLACE CONSTRUCTION

This wood heater must be installed in a full masonry fireplace, which has been carefully inspected for cracks or deterioration. The chimney should be cleaned prior to installation.

You must install a flue the entire length of the chimney. This will help your heater perform to its full capabilities. It is also easier to clean.

## CLEARANCES TO COMBUSTIBLES

The table and diagram below shows the minimum clearances (in millimetres) to combustible materials.

Clearance 'A' is from the top of the hearth to the underside of the combustible mantelpiece.

Clearance 'B' is between the combustible surround columns.

	A	B
Small Insert	1420	820
Medium Insert	1670	880
Large Insert	1720	980

All dimensions are in millimetres

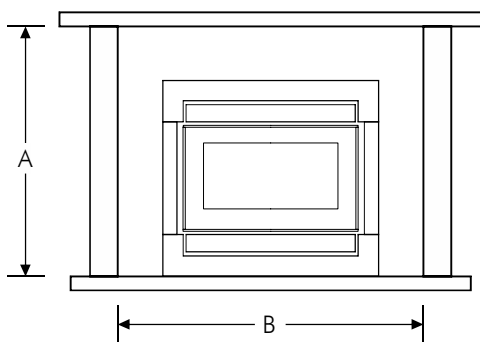

## REDUCED CLEARANCES

The 'Clearances to Combustibles' can be reduced with proper heat shielding, which must be installed in accordance with AS/NZS 2918.

## HEARTH CONSTRUCTION

Do not build the hearth over the front of the heater as this will prevent access to the fan through the front bottom air inlet cover.

The hearth shall consist of no less than 30 mm thick compressed fibre cement sheet with a 15 mm air gap underneath. The cement sheet shall have a thermal conductivity not greater than 0.33 W/m<sup>2</sup>K. The air gap must provide a minimum of 3,750 mm<sup>2</sup> on each side (eg. two slots of 125 mm x 15 mm ventilation on either side).

	C	D
Small Insert	450	875
Medium Insert	500	935
Large Insert	600	1035

All dimensions are in millimetres

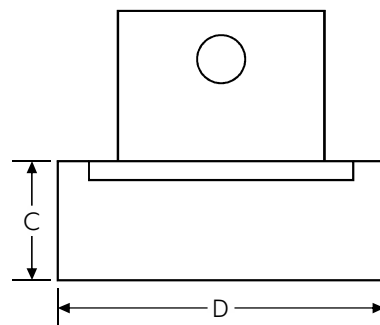

Dimensions	E	F	G	H	J
	firebox width	firebox depth	firebox height	facia width	facia height
All dimensions are in millimetres					
Small Insert	578	416	622	761	696
Medium Insert	638	466	672	821	746
Large Insert	738	566	722	921	796

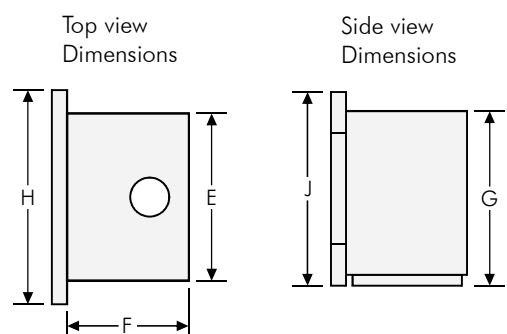

# WOOD SELECTION

Few things affect the performance of your heater as much as the fuel you burn. Take note of the following:

## WHAT NOT TO BURN

- \* Softwood (except kindling)
- \* Wet or unseasoned wood
- \* Treated or painted timber
- \* Saltwater wood
- \* Coal or charcoal
- \* Garbage, plastic etc
- \* Any solvents, kerosene, petrol or any flammable liquid.

## WHAT TO BURN

Quite simply, dry seasoned hardwood.

From when wood is first cut down, it takes up to 12 months of dry storage for the wood to season properly. The seasoning process is underway when cracks begin to appear at the ends of cut timber.

Use of moist or unseasoned wood will result in excessive smoke, longer startup times, a lazy flame that requires more air to stay alight, creosote build up in the flue and on the door glass, and a much less powerful fire. The reason is simple. Heat that would normally be going into the room is wasted boiling water that is trapped inside the wood. This poor performance costs you money in wasted fuel and increased maintenance.

It is difficult to determine if wood is dry just by looking at it. If you can hear the wood sizzle and hiss, or can see moisture bubbling from the wood surface, then your wood is too wet. In practice, the best thing you can do is to be sure of the source. Buy your wood from reputable wood merchants. Make sure you store the wood correctly.

## WOOD STORAGE

It is important that wood be stored under cover. Even wood that is years old will absorb large quantities of moisture if exposed to the elements.

It is advisable that wood is stacked to allow some air flow in and around the logs. This will help keep the wood dry.

## WOOD SPLITTING

It is best to have on hand a good range of wood sizes to help control the fire. The rule of thumb is: the hotter the fire, the bigger the log you can put in.

- \* You need very small pieces of kindling to get the fire started efficiently.
- \* Small pieces up to about 50mm thick are good when the fire is still being established, or when you want to revive a fire that has burnt low.
- \* Larger logs are excellent for long burns once the fire is well established.

# USING YOUR HEATER

Before using your wood heater, study this entire section carefully. It will assist you in achieving maximum efficiency and enjoyment.

## CURING THE PAINT

Various parts of your heater have been coated with high quality paints to protect them and to give them an attractive finish. You will need to “break-in” your heater to harden or cure these coatings.

While curing, be careful not to touch the painted surfaces as the paint will be quite soft.

The basic rule is: cure slowly, over about three burns, without a hot fire. During the curing process it is normal for some smoke and smell to be given off from the surface of the heater. Each time, some windows should be opened to allow the paint odours to escape. Using a fan also helps disperse the odours. For this reason it is best done during the day.

1. The first fire should be kindling only and should last for about 20 minutes. Leave the door slightly ajar to stop the door rope from sticking.
2. Once the heater has cooled down, repeat the process.
3. The third fire should be a normal fire of at least 45 minutes.

By this time, your heater should be cured. In colder conditions, or if the heater uses a fan, it may take slightly longer. The house should be ventilated until all odours are gone.

## OPERATING THE AIR CONTROL

You can control whether your heater burns on high or low with the air control lever found on either the front or the side of the heater, depending on the model. The high and low positions are clearly marked on all models.

If you have an insert model, please use the handle extension rod to adjust the air slide.

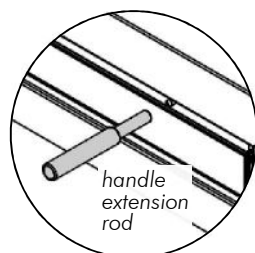

For low burns - Use this setting for low burning, or for extended burn times.

For medium burns - This is the optimal setting for normal use.

For high burns - Use this setting for starting the fire and for at least 30 minutes after loading and reloading.

## LIGHTING THE FIRE

Wood burns most efficiently when placed in a very hot fire. These procedures are designed to bring your firebox to the right temperature as quickly as possible.

Put the air control on high.

Place a large amount of kindling in a criss-cross pattern over a firelighter. Make sure plenty of air can get into the stack and around each piece of kindling.

Add a few small pieces of wood on top.

Ignite the firelighter.

Continue to add small pieces of wood until a bed of hot glowing coals is established.

Place two or three thoroughly dry split logs (about 80-100 mm diameter) on the well established fire. Logs will burn better if they are placed with their ends near the glass, ie front to back.

Leave the air control on high for about 30 minutes. After this time, the firebox should be hot enough for normal operation, so you can turn down to medium or low.

Adding fresh wood cools the fire down, so when you need to replenish the fuel, turn the air control to high for about 30 minutes to bring the firebox temperatures back up to normal

Always leave the air control on high for at least 30 minutes after reloading.



# USING YOUR HEATER

## *A FEW HINTS*

Wood should be stacked front to back - with the ends facing the door - and with space between them for air to flow around.

The door should remain closed at all times except when first establishing the fire and when loading.

There are many factors that can affect the way your heater burns, including flue height, wood type, shape, amount, the way it is stacked, wind conditions and outside air temperatures to name a few. You will find that before long you will get to know how your heater works best for you.

## *OVERNIGHT BURNS*

Large unsplit logs are the best fuel to use.

Make sure you have a good strong bed of glowing coals and the heater is hot before loading the logs.

Place a load of wood on the strong base fire and coals, shut the door and leave on high for about 30 minutes or until the logs are charred all over.

Turn down to low.

## *RESTARTING AFTER AN OVERNIGHT BURN*

Adjust air control to high.

Rake the hot coals.

Place some kindling and small logs on the coals.

Once the fire is established, start putting on larger logs.

## *REMOVING ASHES*

When the ashes are level with the firebox opening, it's time for a clean out. This should only be done when the firebox has completely cooled. Removing hot ashes is hazardous.

Push chunks of charred wood to one side. These will burn in the next fire, so it would be a shame to waste them. Using a metal scoop, remove excess ash and place in a metal container.

You should leave a small amount of ash in the firebox to provide an insulating base for the next fire. Rake them over so they form a flat bed.

When disposing of the ashes, keep them in a metal or other non-combustible container with a tight fitting lid. Move them outdoors immediately to an area clear of combustible materials. Do not place them in plastic receptacles.

## *HEATER FANS*

Your Kent heater is fitted with a fan. The fan should only be used on "high" or "boost" when the air control is on the maximum setting.

The fan should never be used when the air setting is on "low" or overnight setting.

We also recommend not using the fan until 30 minutes after the fire is first lit.

The fan installed in your heater is fitted with an over temperature safety device.

The fan may stop if the pre-set temperature is exceeded. The fan will restart when it has cooled to a safe temperature. This is normal operation for this safety device.

# CARE AND MAINTENANCE

Your heater has been designed as a heavy duty appliance capable of withstanding normal operating conditions.

## CARE

The firebox liners where fitted must be treated with care. Avoid throwing logs into the firebox as this may fracture the liners.

## CLEANING

To clean painted surfaces, wipe over with a soft, damp cloth. Do not use harsh solvents and cleaning agents as these can damage the coating. Buff dry with a soft, dry cloth.

If your heater is installed in a coastal environment, where salt air will come in contact with the heater, this cleaning process should be performed weekly to avoid the salt causing deterioration of the paint and subsequently rust.

Door glass: sometimes black deposits will build up on the inside of the door glass. To remove this build up, rub gently with a plastic scourer pad moistened with water and detergent. Then use the damp and dry cloths as before. Hot glass cleaner is also available from your heater retailer.

## ROUTINE MAINTENANCE SCHEDULE

At beginning of the season and at least every 8 weeks during the season

- \* Inspect and clean the flue system. To do this, remove the baffle plate and flue cowl, and clean out with a flue brush.
- \* Check the painted surfaces. If there is any wear, for instance from cleaning or abrasion, touch up paint is available from your dealer.

At end of season

- \* Inspect the door glass for any cracks and replace if necessary.
- \* Inspect door rope and seals and replace if necessary.
- \* Inspect firebox for wear or excessive corrosion.
- \* Inspect firebricks where fitted and replace if broken.

- \* Check that the air slide moves smoothly. If it is sticky, lubricate it with high temperature grease available from your local hardware store.

## CREOSOTE BUILD UP

When the heater is continually burnt with lower than normal fire temperatures, eg due to unseasoned wood, higher than acceptable amounts of smoke are produced which condense on the inside of the flue. This builds up as a black, tar-like deposit called creosote.

A thin layer of creosote inside the flue is normal and will not cause a problem. Once there is a layer more than 3mm thick, problems can occur.

1. If the layer is thick enough, it restricts the flue and can cause insufficient draw and even smoke spillage back into the house.
2. More seriously, creosote is combustible, and can ignite. A flue fire is easy to detect, involving a roaring sound, a vibration of the flue, and sometimes flames and sparks shoot out of the top of the flue.

To avoid creosote build up and the fires that may result, burn seasoned wood with the air control set to medium or high for most of the time.

To remove creosote when it does build up, remove the baffle plate and flue cowl, and use a flue brush to clean the flue system. To remove the baffle plate, slide the plate up on one side and then down around the brackets on the other.

In case of a flue fire, do not panic. Your flue system has been constructed to withstand high temperatures. Immediately close the air control down to its lowest setting. Do not open the door. Once the fire has extinguished, you should have your flue system inspected by a qualified service person.

# CARING FOR THE ENVIRONMENT

*Caring for our planet means reducing pollution and managing our resources intelligently. Every resource we use today we are borrowing from our future generations.*

*The key to successfully meeting our future energy requirements lies in our ability to manage existing resources wisely. Unlike fossil fuels such as oil, coal and gas, wood can be managed on a sustainable basis.*

*This is why wood is one of the wisest, most cost effective and environmentally efficient forms of home heating available today.*

*You can make a further positive contribution to the environment by following these important steps:-*

## OPERATING YOUR HEATER

- \* Always burn good, dry hardwood. This will yield the greatest amount of heat for the least amount of fuel.
- \* Never burn green or unseasoned wood, or wood that is wet. This will waste energy, cause excessive smoke and reduce the performance of your wood heater.
- \* Do not allow your wood to smoulder. Your fire should always burn brightly and cleanly. Check the flue occasionally to see if there is any excessive smoke.

## OTHER THINGS YOU CAN DO

- \* Ensure your home is adequately insulated. This will reduce your energy requirements, and lessen your fuel bills, or the need to gather fuel. This in turn reduces pollution.
- \* Do not overheat your home! If you feel hot even when wearing light clothing, then you are wasting energy.
- \* Install ceiling fans in the main rooms. These are an excellent investment in year round comfort. Because hot air rises, ceiling fans push this hot air back closer to ground level to keep you warmer.

## LANDCARE

A portion of the sale of your heater is donated directly to Landcare by the Australian Home Heating Association.

Landcare is one of the most proactive community based environmental groups in Australia today. Almost 5000 Landcare groups have sprouted across Australia and like the millions of trees Landcare has planted, they're still growing. One of three farmers is a member of Landcare.

These groups get involved in activities like tree planting and revegetation, weed removal, fencing, feral animal control, water quality monitoring, nature surveys, riverbank repair, and sustainable agricultural techniques.

Landcare groups are usually formed because there is a problem. Locals notice changes in their environment and decide to do something about it. Landcare groups can grow out of neighbouring farms, or neighbours in the city that share a local park. Landcare groups are working on all imaginable ecosystems in Australia, from dry and dusty central Australia, to tropical rainforests of Queensland and the mountains in Tasmania.

**WOOD HEATING IS GOOD HEATING**



## NEED ACCESSORIES?

Your Kent dealer also sells a range of attractive, good value accessories for your heater like mesh guards, tool sets and wood baskets.

Also, you can ask about maintenance products, firelighters, touch up paint, flue cleaning products and more.

G.L.G. Australia Pty Ltd  
Building A2, Campus Business Park  
350-374 Parramatta Road  
Homebush NSW 2140

HINS-236A  
29042020